

SDP-Eco 1630 IIR

Silver Digiplate for Polyester- and Paper based printing plates



- Environmentally-friendly CTP system for polyester and paper based printing plates
- Best solution for small format offset printing
- Very compact, high speed system for 4c-printing
- Low investment and production costs
- Ideal introductory CTP system

SDP-Eco 1630 IIIR

SDP-Eco 1630 IIIR is for small and mid-sized offset printing houses. The system offers a perfect CTP solution at low investment and production costs.

Incredible productivity

With a maximum resolution of 2400 dpi you can expect high quality images. The system offers a maximum print run length of 20,000 impressions, perfect for all commercial printing applications.

Mitsubishi SDP-RIP

This platesetter comes complete with one of the most efficient CTP RIPs in the industry- the Harlequin based SDP-RIP automating the front-end of your prepress workflow. The continuously developed SDP-RIP is a multi-device software that triggers various output devices. When operating the RIP, no additional adjustment need to be made at the platesetter.

Environmentally-friendly CTP system

The SDP-Eco 1630IIIR's patented Eco processing technology provides extremely stable plate development. It does so by applying a thin layer of chemicals to the plate surface. This lowers your costs and saves time by reducing your maintenance. Add to this low energy consumption and you have a very environmentally-friendly CTP system.

Technical Specifications SDP-Eco 1630 IIIR

Recording	Capstan
RIP	Mitsubishi SDP-RIP
Light Source	Red Laser Diode (635 nm)
Resolution	1200, 1500, 1800, 2400 dpi
Recording Speed	81 plates/h at 1200 dpi, 69 plates/h at 1500 dpi 53 plates/h at 1800 dpi, 29 plates/h at 2400 dpi
Output Media	Silver Digiplate Material SDP-FRS175 (61m), SDP-FR100 (61 m), SDP-RR175 (75m)
Plate Width	max. 414 mm, 454 mm (optional)
Maximum Recording Width	404 mm
Plate Length	220 to 580 mm
Developing System	Coating Type Development, „Eco“ Processor
Chemicals	SDP-EACII (Activator), SDP-ESTII (Stabilizer)
Tank Capacity	SDP-EACII: 0,55l, SDP-ESTII: 0,6l, Wash-off Water: 0,26l
Power Requirements	50/60 Hz, 230 V, 1.2 kW
Dimensions	1000 (W) x 795 (D) x 1070 (H) mm, 207 kg
Environment	23°C ± 5°C, 50-70% relative humidity
Options	Reference Punch

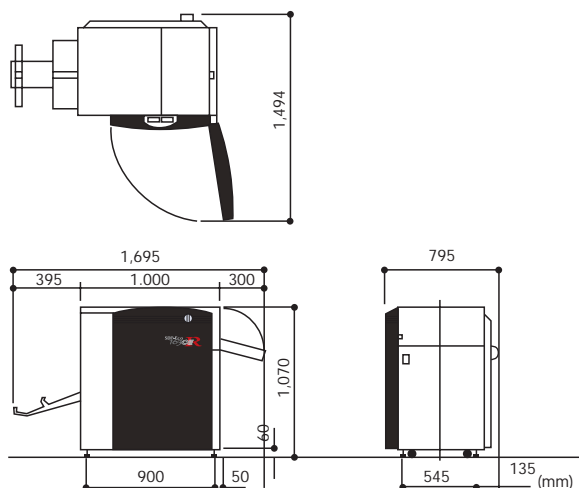

Mitsubishi Paper GmbH
Am Albertussee 1
40549 Dusseldorf
Phone ++49 (0) 211 / 535 96 200
Fax ++49 (0) 211 / 535 96 222
www.mitsubishi-paper.com

Mitsubishi International GmbH
Kennedydamm 19
40476 Dusseldorf
Phone ++49 (0) 211 / 4397 369
Fax ++49 (0) 211 / 4397 461
www.mitsubishicorp-de.com

Mitsubishi Imaging (MPM) Inc.
555 Theodore Fremd Avenue
Rye, N.Y. 10580, USA
Phone ++1 914 / 925 3200
Fax ++1 914 / 925 2495
www.mitsubishiimaging.com

MITSUBISHI PAPER MILLS LIMITED

Head Office Fuji Building, 2-3, Marunouchi 3-chome, Chiyodaku, Tokyo 100-0005, Japan,
Phone ++81 3 3213 3744, Fax ++81 3 3214 5936, www.mpm.co.jp