

# Thermal Digiplate

Process-free CTP system for paper based offset printing plates



- Thermal CTP plate on RC-coated paper base
- Truly chemical- and process-free
- Fully-automatic 2-up CTP system
- Output speed: 60 plates/h

# Thermal Digiplate

Mitsubishi Paper Mills has developed the Thermal Digiplate System which is an environmentally-friendly CTP solution featuring easy operation and maintenance. This CTP solution is based on years of experience in black and white printing. Thermal Digiplate from Mitsubishi is the genuinely, processless 2-up CTP solution. The system is based on MPM's unique silver halide printing plate technology (Silver Digiplate) and imaging technology of thermal paper.

## Features of the Thermal Digiplate Platesetter

- The exclusive system developed by Mitsubishi Paper Mills is working with a thermal line head
- The system is optimized for the 2-up format with a resolution of 1200 dpi/120 lpi
- No chemicals, toner or ink ribbon are necessary, making for easy maintenance
- Output speed: 60 plates/h

## Features of the Thermal Digiplate offset printing plate

- Truly processless CTP paper based plate
- Absolutely no chemicals are required for the processing of the printing plates
- High image contrast, good repeatability and easy control of the images
- The resin coated paper plate is available in rolls

## Technical specifications

Plate Size	310 mm x 492 mm to 459 mm x 525 mm
Dimensions	514 x 662 x 385 mm (W x D x H)
Weight	60 kg
System Conf.	Windows 2000 Professional Windows XP Windows Vista
Option:	TDP Controller Software (1-bit TIFF)

## Thermal Digiplate Imaging

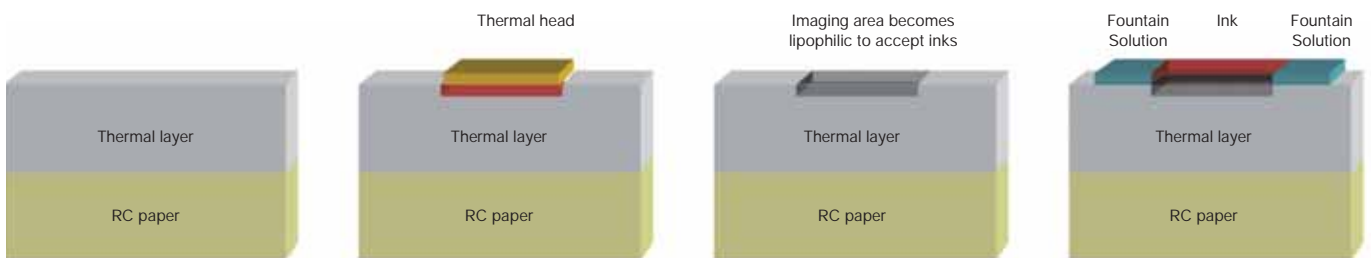

## Thermal Digiplate – Dimensions

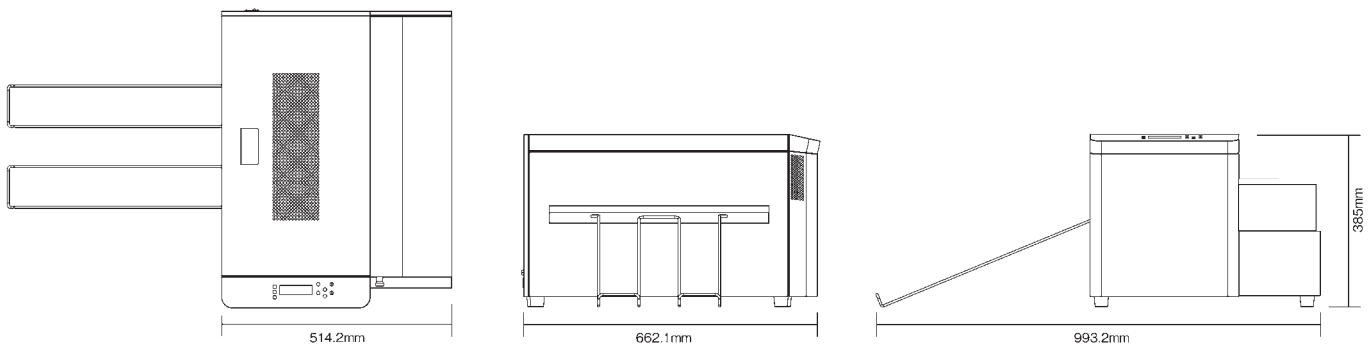

**Mitsubishi Paper GmbH**  
Am Albertussee 1  
40549 Dusseldorf  
Phone ++49 (0) 211 / 535 96 200  
Fax ++49 (0) 211 / 535 96 222  
[www.mitsubishi-paper.com](http://www.mitsubishi-paper.com)

**Mitsubishi International GmbH**  
Kennedydamm 19  
40476 Dusseldorf  
Phone ++49 (0) 211 / 4397 369  
Fax ++49 (0) 211 / 4397 461  
[www.mitsubishicorp-de.com](http://www.mitsubishicorp-de.com)

**Mitsubishi Imaging (MPM) Inc.**  
555 Theodore Fremd Avenue  
Rye, N.Y. 10580, USA  
Phone ++1 914 / 925 3200  
Fax ++1 914 / 925 2495  
[www.mitsubishiimaging.com](http://www.mitsubishiimaging.com)

## MITSUBISHI PAPER MILLS LIMITED

Head Office Fuji Building, 2-3, Marunouchi 3-chome, Chiyodaku, Tokyo 100-0005, Japan,  
Phone ++81 3 3213 3744, Fax ++81 3 3214 5936, [www.mpm.co.jp](http://www.mpm.co.jp)