

P-α880

Eco RF CTP-Processor

OPERATING INSTRUCTIONS

Ver.1.02(from S/N 501)



**MITSUBISHI
PAPER MILLS
LIMITED**

P- 880 Eco RF

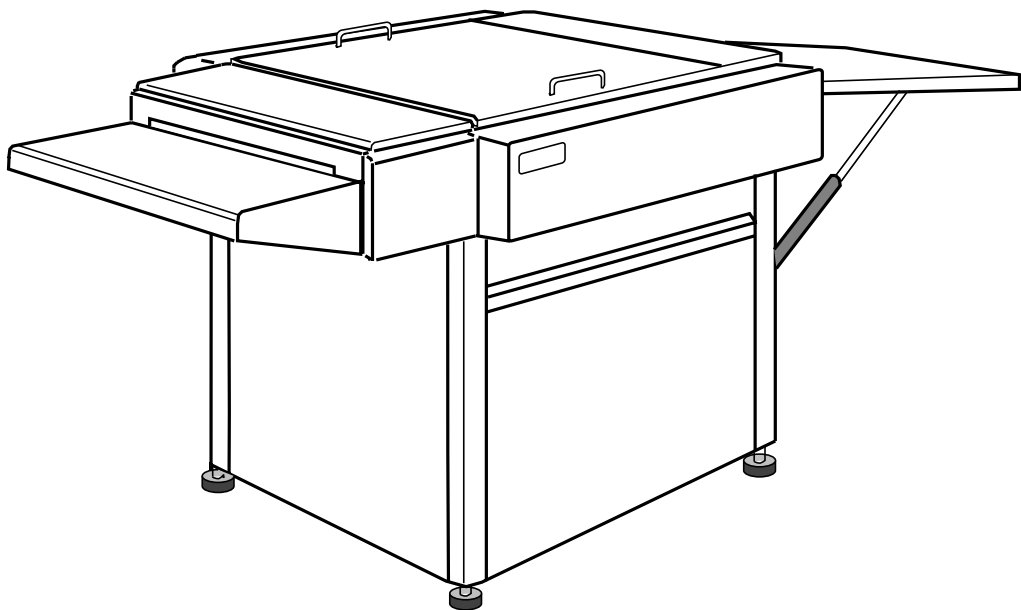

**This manual is for daily users of the equipment.
Always read the *Safety Instructions Manual, part No 21741*,
before starting up the equipment and keep it with the machine for
reference at all times.**

| |
|----------------------------|
| MPM SUPPORT OFFICES |
|----------------------------|

mitsubishi Paper Mills, LTD.

*Shin Nisseki Bldg., 4-2
Marunouchi 3-Chome
Chiyoda-Ku, Tokyo 100
JAPAN
Phone: +81 3-3123-3742
Fax: +81 3-3214-3976
www.mpm.co.jp*

MITSUBISHI IMAGING (MPM), INC.

*555 Theodore Fremd Avenue
Rye, N.Y. 10580
U.S.A.
Phone: +1 800-765-9384
Fax: +1 914-921-2495
www.mitsubishiimaging.com*

MITSUBISHI PAPER GmbH

*Wiesenstrasse 21
40549 Düsseldorf
GERMANY
Phone: +49 211-56849-0
Fax: +49 211-56849-22
www.mitsubishi-paper.de*

This manual is valid for CTP-processors with Eco RF-H & W

0. INTRODUCTION

IMPORTANT!

- **Approvals:** The processor is manufactured according to legal demands. For compliance with the requirements the equipment is tested by Underwriters Laboratories or other accredited authority. Approvals will appear from the labels attached to the processor name plate or the frame part of the processor.
- **Intended use of the equipment :** Development of CTP plates as specified in “TECHNICAL SPECIFICATIONS” in chapter 1 of this manual.
- **Installation:** It is the responsibility of the owner and operator/s of this processor, that the installation is made in accordance with local regulations, and by engineers authorized to carry out plumbing and electrical installations.
Installation, service and repair must be performed only by service technicians who are trained in servicing the equipment.
The installation procedure is described in “INSTALLATION” in chapter 2 in the service manual.
The manufacturer can not be held responsible for any damage caused by incorrect installation of this processor.

- **Technical data:** Observe technical data from the processor name plate located on the rear panel of the processor.
- **Chemicals:** This processor must only be used with chemicals provided by Mitsubishi Paper Mills.
Always obey the product safety data sheets provided by the manufacturer.
- **Lithium Batteries:** Replace only with the same or equivalent type as recommended by the manufacturer.

Dispose of used batteries according to the manufacturer’s instructions.

CAUTION! Make sure always to mount the battery with the positive (+) side upwards.

CAUTION! Danger of explosion if battery is incorrectly replaced.

THIS MANUAL

- **Intended use of this manual:** This manual is for the daily user of the equipment. Always read the **Safety Instruction Manual part No 21741** before starting up the equipment and keep it with the machine for reference at all times.
- **Reservations:** This manual was written and illustrated using the best possible information available at the time of publication. Any differences between this manual and the equipment reflect improvements introduced after the publication of the manual. Changes, technical inaccuracies and typographic errors will be corrected in subsequent editions. As a part of our policy of continuous improvement, we reserve the right to alter design and specifications without further notice.

WARNINGS, CAUTIONS AND NOTES!

Throughout the manual warnings, cautions, and notes are written in bold on a grey background like the example below:

CAUTION! Always replace a fuse with one of the same size and rating as the old one.

Explanation:

NOTE!

The operator should observe and/or act according to the information in order to obtain the best possible function of the equipment.

CAUTION!

The operator must observe and/or act according to the information in order to avoid any mechanical or electrical damage to the equipment.

WARNING!

The operator must observe and/or act according to the information in order to avoid any personnel injury.

HANDLING THE PROCESSING CHEMICALS

The processing chemicals used in this processor are not generally dangerous to humans, but failure to use them in the correct manner is dangerous. Be sure to handle all processing chemicals with maximum care.

CAUTIONS FOR USE OF PROCESSING CHEMICALS

- 1) Thoroughly read the precautions on safety in the manual for processing chemicals and perform service work in accordance with the instructions on the warning labels attached to the processing chemicals.
- 2) Provide well-ventilated area in which the processing chemicals are used.
- 3) For your safety, when using the processing chemicals be sure to wear protective gear, such as non-permeable gloves, goggles, and mask. After work, be sure to wash your hands.
- 4) The processing chemicals can injure your eyes, irritate your mucous membrane, or cause allergic reaction depending on your constitutional predisposition. Be careful to avoid the processing chemicals from directly making contact with your eyes, skin, or clothing.
- 5) The processing chemicals are toxic and not to be ingested. Be careful to avoid swallowing or taking the processing chemicals in your mouth.
- 6) If any processing chemical enters your eyes or contacts your skin, immediately take off the contaminated clothing or shoe(s) and flood the affected area with copious quantities of water for at least 15 minutes. After that consult a physician as soon as possible.
If you reuse the clothing or shoes, be sure to completely wash them.
- 7) If anyone has swallowed any processing chemical, immediately call ambulance and follow the instructions from medical staff. Unless otherwise instructed by medical staff, you must neither induce vomiting nor give anything to eat or drink.
- 8) If anyone has inhaled any processing chemical, move him/her to a place that offers fresh air, and consult a physician as soon as possible. If he/she does not breathe, practice artificial respiration.
- 9) Keep the processing chemicals out of reach of children.
- 10) Handle the processing chemicals with care to avoid your hands or any other part of your body being cut by a sharp edge or a jagged end of the package of the processing chemical.
- 11) To avoid the containers of processing chemicals from falling, which can injure you, do not put them in a high place or stack them highly.
- 12) Properly dispose of the waste materials, such as empty packages, waste chemicals, and media with chemicals, so that they will not contact to human body directly.

DESCRIPTION OF WARNING LABELS

Before using the processor, be sure to read description in this section.

Handling the machine incorrectly or neglecting the safety instructions may cause hazard of accidents, such as fire and electrical shock.

The warning labels are used to alert the users, operators, and service persons of this machine to these possible hazards mentioned above.

Three types of headings are used for the cautions labels: HAZARD, WARNING, and CAUTION, which reflect the relative level of potential danger.

HAZARD! : Indicates an imminently hazardous situation which, if not avoided, could result in death or serious injury.

WARNING! : Indicates a potentially hazardous situation which, if not avoided, could result in death or serious injury.

CAUTION! : Indicates a potentially hazardous situation which, if not avoided, may result in minor or moderate injury.

These words are also used for works that contain hazards.

“HAZARD” and “WARNING” are not used for hazardous situation, which could (may) result in only property damage but no human injury.

“ATTENTION” indicates a situation less hazardous than that mentioned in the CAUTION label above or gives a precaution for use.

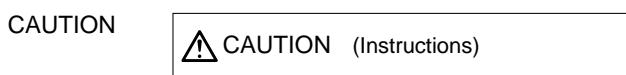
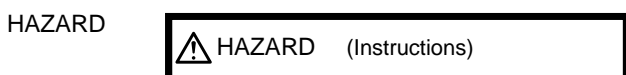

WARNING LABELS AND INSTRUCTIONS

The types of warning labels (HAZARD, WARNING, CAUTION), potential hazards, and instructions to avoid such hazards are described below.

All operators and maintenance/service personnel must follow the instructions written on these labels.



WARNING

There are sections where the voltages are dangerously high. Direct contact with these sections (marked with this label) can cause severe shock and potentially fatal injuries.

Safe handling method

Only maintenance/service staff can open the peripheral cover and attempt to touch inside. The maintenance/service staff must turn OFF the main power supply and the power switch on the machine before approaching.

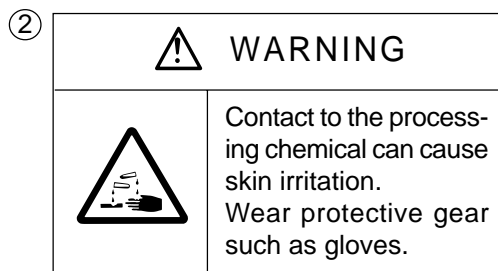

WARNING

Contains processing chemicals. Direct contact with these chemicals due to splashing or overflow may result in skin irritation, blindness, or burns.

Safe handling method

Read all instructions and warnings for processing chemicals. Always wear protective gear such as safety goggles, rubber gloves, masks, and rubber aprons.

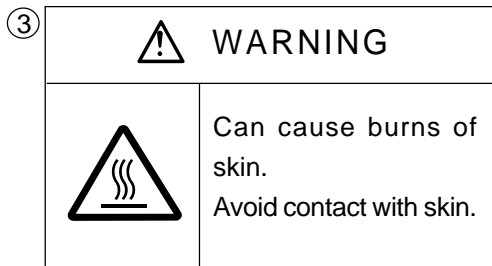
**WARNING**

The parts or areas marked with this label are extremely hot. Direct contact with these parts or areas may cause serious burns.

Safe handling method

Do not touch with bare hands. Be sure to wear heat-resistant gloves when touching these extremely hot parts/areas. When you wear no gloves, confirm that the parts/areas are sufficiently cool.

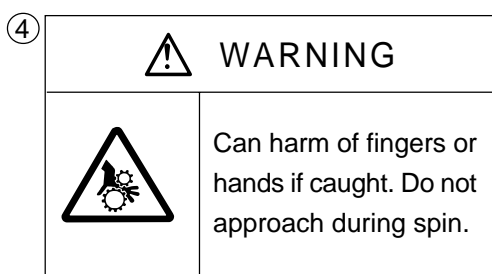
**WARNING**

Hand or fingers may get caught.

Safe handling method

Keep hands, fingers and the rest of the body away during operation. Be sure to turn OFF the main power supply and the power switch on the processor before approaching.

● The locations of the warning labels (DANGER, WARNING, CAUTION) are described below.

Left side of the main body

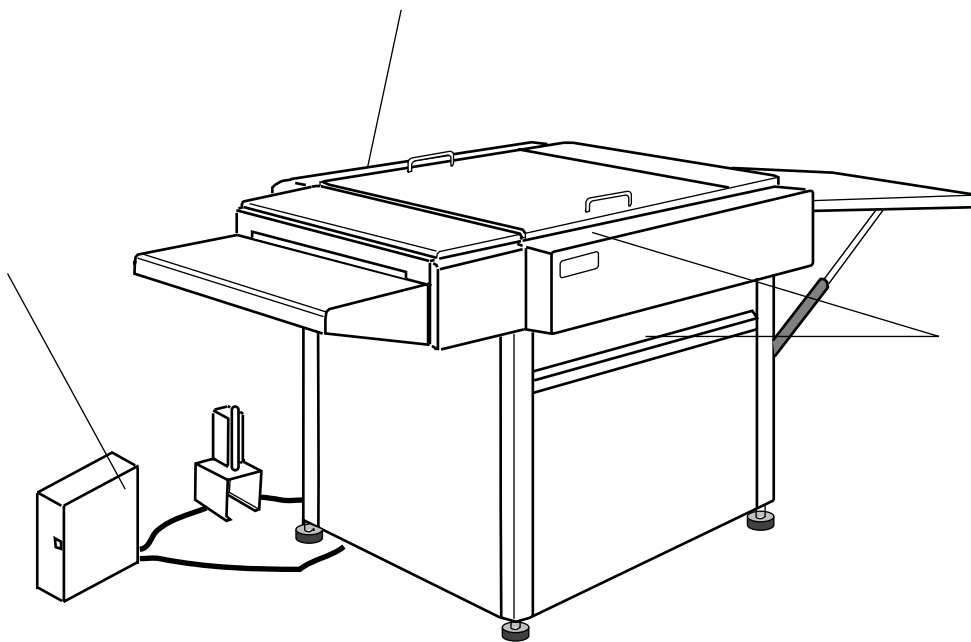

Right side of the main body

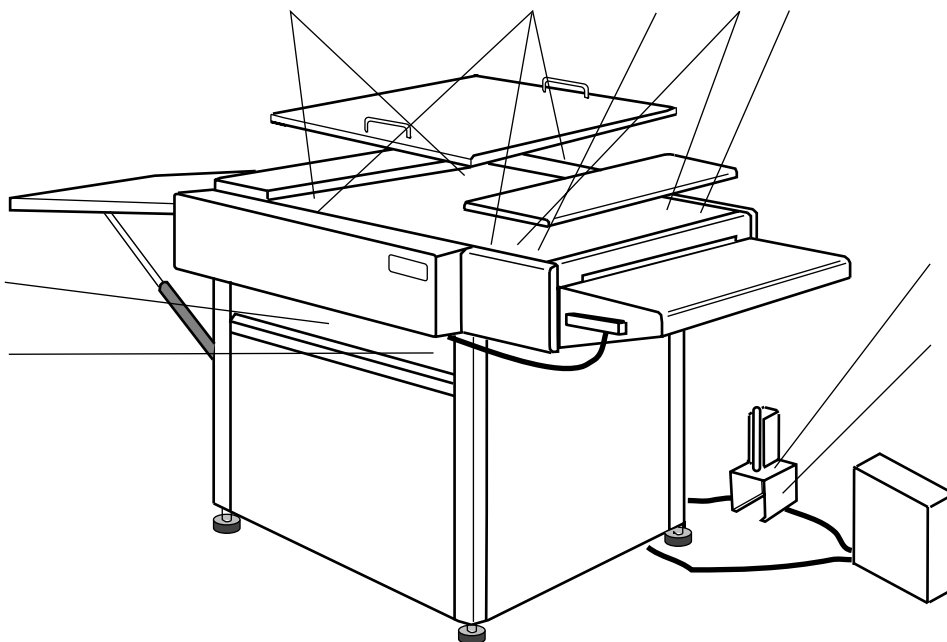

| |
|--------------------------|
| TABLE OF CONTENTS |
|--------------------------|

| | PAGE |
|---|-------------|
| 0. INTRODUCTION | 3 |
| IMPORTANT! | 3 |
| THIS MANUAL | 4 |
| WARNINGS, CAUTIONS AND NOTES! | 4 |
| HANDRING THE PROCESSING CHEMICALS | 5 |
| CAUSIONS FOR USE OF PROCESSING CHEMICALS | 5 |
| DESCRIPTION OF WARNING LABELS | 6 |
| WARNING LABELS AND INSTRUCTIONS | 6 |
| | |
| 1. TECHNICAL SPECIFICATIONS | 13 |
| 1-1. PROCESSING MATERIAL | 13 |
| 1-2. ELECTRICAL SPECIFICATIONS | 13 |
| 1-3. MECHANICAL SPECIFICATIONS. | 13 |
| 1-4 DIMENSIONS | 14 |
| 1-5. WEIGHTS | 14 |
| | |
| 2. FUNCTIONAL DESCRIPTION | 15 |
| 2-1. GENERAL | 15 |
| 2-2. MAIN COMPONENTS OVERVIEW | 17 |
| 2-3. FUNCTIONAL DESCRIPTION | 21 |
| DEVELOPER SECTION | 21 |
| WASH-OFF 1 & 2 SECTIONS | 23 |
| GUM SECTION | 27 |
| DRYER SECTIONP | 28 |
| RE-PROCESS SECTION | 28 |
| | |
| 3. CONTROLS AND INDICATORS | 29 |
| 3-1.THE CONTROL BOX | 29 |
| CONTROL PANEL LIGHT | 30 |
| FUNCTIONAL DESCRIPTION | 30 |
| ERROR/AUTO-START CODES | 39 |

| |
|--------------------------|
| TABLE OF CONTENTS |
|--------------------------|

| | PAGE |
|--|-------------|
| 4. OPERATING PROCEDURES | 41 |
| 4-1. OPERATING MODES | 43 |
| 4-2. DAILY START-UP | 47 |
| 4-3. SETTING THE PROCESSING PARAMETERS | 47 |
| 4-4. PROCESSING FROM THE FEED TABLE | 49 |
| 4-5. USING THE REWASH SLOT | 51 |
| 4-6. SHUTDOWN PROCEDURE | 53 |
| NORMAL SHUT DOWN | 53 |
| COMPLETE SHUTDOWN | 53 |
| | |
| 5. CLEANING AND MAINTENANCE | 55 |
| 5-1. GENERAL | 55 |
| CLEANING ACCESSORIES | 56 |
| CLEANING AGENTS | 56 |
| BEARING BLOCKS | 57 |
| SPRAY TUBES | 57 |
| IDENTIFICATION OF ROLLERS | 59 |
| 5-2. CLEANING/MAINTENANCE INTERVALS | 60 |
| 5-3. SAFETY CHECK | 61 |
| 5-4. CHECK OF CONTAINER CONTENTS | 62 |
| RESETTING OF THE CONTAINER LEVEL FUNCTION | 62 |
| 5-5. CLEANING, PROCESSOR EXTERIOR | 63 |
| 5-6. LUBRICATION, GEARS | 63 |
| 5-7. CHANGING.CLEANING OF FILTERS | 64 |
| 5-8. CLEANING, DEVELOPER SECTION | 65 |
| NORMAL CLEANING | 65 |
| 5-9. CHANGING THE DEVELOPER | 66 |
| DEVELOPER (CUBITAINER) REPLACEMENT PRPCEDURE | 66 |
| CLEANING THE DEVELOPER SECTION | 67 |
| REPLACING DEVELOPER | 67 |
| BLEEDING PROCEDURE | 68 |
| DEVELOPER SECTION MANAGEMENT IN CASES WHEN MACHINE IS LEFT OFF | 69 |

| |
|--------------------------|
| TABLE OF CONTENTS |
|--------------------------|

| | PAGE |
|---|-------------|
| 5-10. REMOVING THE BRUSH.STOP ROLLER | 70 |
| 5-11. REPLACING THE BRUSH ROLLER CLOTH | 71 |
| 5-12. CLEANING, WASH-OFF SECTION | 72 |
| 5-13. CHANGING THE WASH-OFF SOLUTION | 73 |
| 5-14. CLEANING, GUM SECTION | 74 |
| NORMAL CLEANING | 74 |
| RUNNING THE GUM-RINSE PROGRAM | 74 |
| WEEKLY CLEANING | 75 |
| CLEANING OF THE GUM GRATE | 75 |

1. TECHNICAL SPECIFICATIONS

1-1. PROCESSING MATERIAL

PLATE WIDTH

RF-W:10 - 82 cm (4 - 32.3"),
RF-H:10 - 64.5 cm (4 - 25.4")

PLATE LENGTH

34 - 103 cm (13.4 - 40.6")

PLATE THICKNESS

0,15 - 0,3 mm (0.006 - 0.012")

1-2. ELECTRICAL SPECIFICATIONS

POWER SUPPLY

180 - 230 V AC, single phase + PE, 50-60 Hz
fused by 16 A
or
230 - 254 V AC, single phase + PE, 50-60 Hz
fused by 16 A

POWER CONSUMPTION

Max: 2850 Watt

1-3. MECHANICAL SPECIFICATIONS

PLATE SPEED

50 - 240 cm/min. (19.7 - 94.5 in/min)
105 cm/min is standard.

BRUSH SPEED

40 - 120 rpm. 100rpm is standard.

DRY-TO-DRY TIME

Min: 30 sec.
Max: 100 sec.

TEMPERATURES

Pre-Process section: 30 - 70°C (86 - 158°F)
Wash-Off: 30 - 35°C (86 - 95°F)
Dryer operate: 30 - 65°C (86 - 149°F)
Operating Room: 20 - 30°C(68 - 86°F)

TANK VOLUMES

(Incl. circulation system/filters)
Dev: 0
Wash-Off 1: 14,6 litres (3.9 US gal.)
Wash-Off 2: 6 litres (1.6 US gal.)

1-4.DIMENSIONS

(See illustration below)

Width (**W**) :122 cm (48")

Depth (**D1**): 286 cm (incl. exit table) (112.6")

Depth (**D2**): 176 cm (excl. exit table) (69.3")

Depth (**D3**): 134 cm (body) (52.8")

Depth (**D4**): 105 cm (tray, option) (41.3")

Height (**H**) : 95 cm incl. adj. legs (37.4")
for Off-line

Height (**H1**): 99 cm incl. adj. legs (39")
for Off-line

Height (**H2**): 93 cm incl. adj. legs (36.6")
for DS PF-R1050 etc.(On-line)

Height (**H3**): 104 cm incl. adj. legs (40.9")
for DS PI-R2080, Agfa Galileo
etc.(On-line)

1-5. WEIGHTS

Empty: App. 232 kg

With chemicals: App. 252 kg

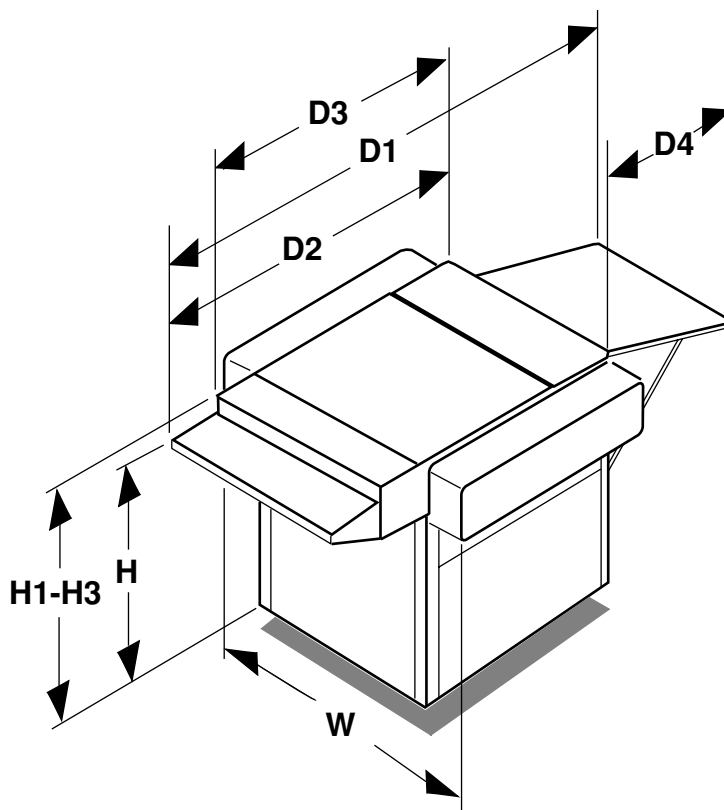

2. FUNCTIONAL DESCRIPTION

2-1. GENERAL

This processor contains 6 major sections (see the illustration below): pre-process (H), developer (A), wash-off 1 (B), wash-off 2 (C), gum (D), and dryer (E) sections. Each section performs a basic function to develop exposed plates and dry them to make plates available for printing.

Plate material is fed into the processor through the feed-table (F) (when the processor is offline). At this stage, the processor is usually in the STANDBY mode. It then switches to the PROCESS mode as soon as the input sensor activates. (Refer to “Operating modes”.)

Once a plate is fed into the processor, the transport roller system takes over and leads the plate safely and smoothly through each of the 6 major sections.

After the plate is discharged from the processor onto the exit table (G), the processor returns to the STANDBY mode.

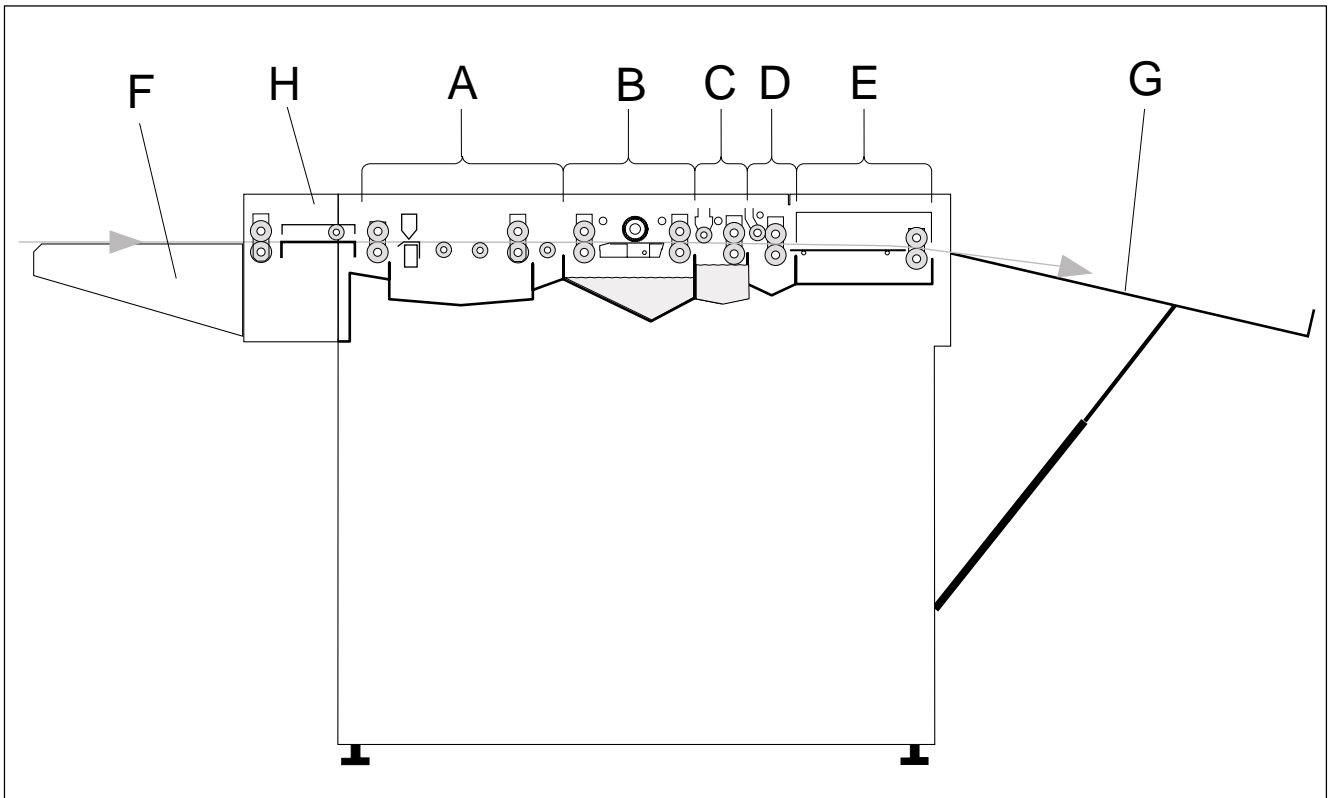

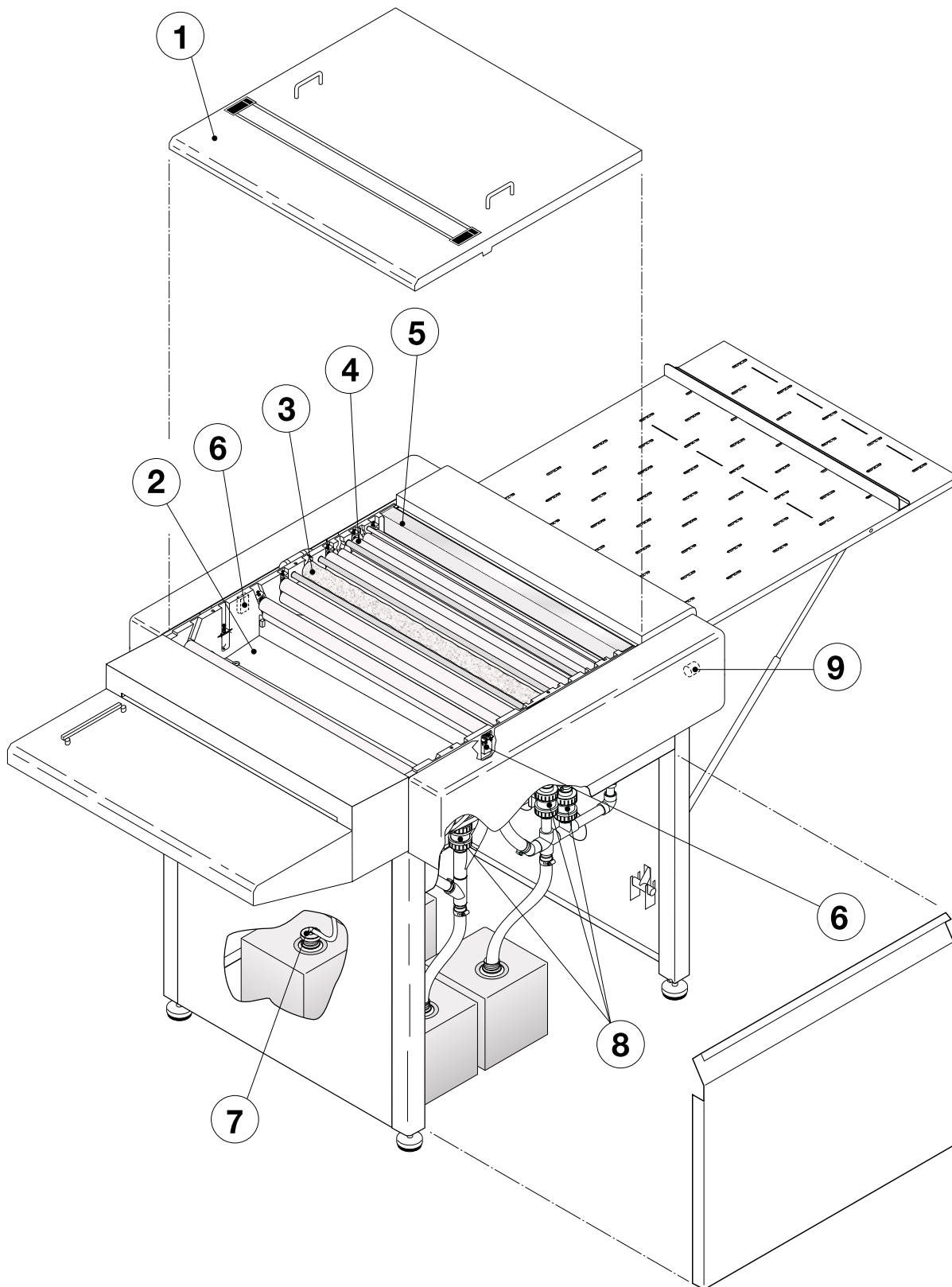

2-2. MAIN COMPONENTS OVERVIEW

(See illustration opposite).

TOP COVER (1)

The top-cover can easily be removed when performing service and maintenance.

When the top cover is lifted off, the interlock switches (6) turn off the power to all moving parts (rollers, pumps etc.) of the processor.

The top cover is equipped with a rewash-slot that makes it possible to enter a processed plate for washing-off, gumming and drying.

DEVELOPER SECTION (2)

See description in "DEVELOPER SECTION" later in this chapter.

WASH-OFF SECTION (3)

See description in "WASH-OFF SECTION" later in this chapter.

GUM SECTION (4)

See description in "GUM SECTION" later in this chapter.

DRYER SECTION (5)

See description in "DRYER SECTION" later in this chapter.

INTERLOCK SWITCHES (6)

The processor is equipped with 2 interlock switches, one on each side of the tank.

When the top cover is lifted off, the interlock switches turn off the power to all moving parts (rollers, pumps etc.) of the processor.

Note! When the top cover is lifted off, the only developer pump can run.

SUCTION TUBES (7)

Each replenishment hose is fitted with a special suction tube. When inserted into a replenishment container the suction tube ensures a tight fit preventing oxidation of the solution.

Additionally the tubes are fitted with small filters to keep impurities out of the replenishment hoses.

DRAIN VALVES (8)

The developer- and wash-off sections are fitted with drain valves underneath the tank.

Use the drain valves to empty the sections when performing cleaning of the tanks or when exchanging the solution in the tanks.

COOLING UNIT PLUG (9)

P- α 880 processor should be connected to a developer cooling unit, a plug for the electronic connection is provided behind the right cover. However, it is not used by Eco RF processor now.

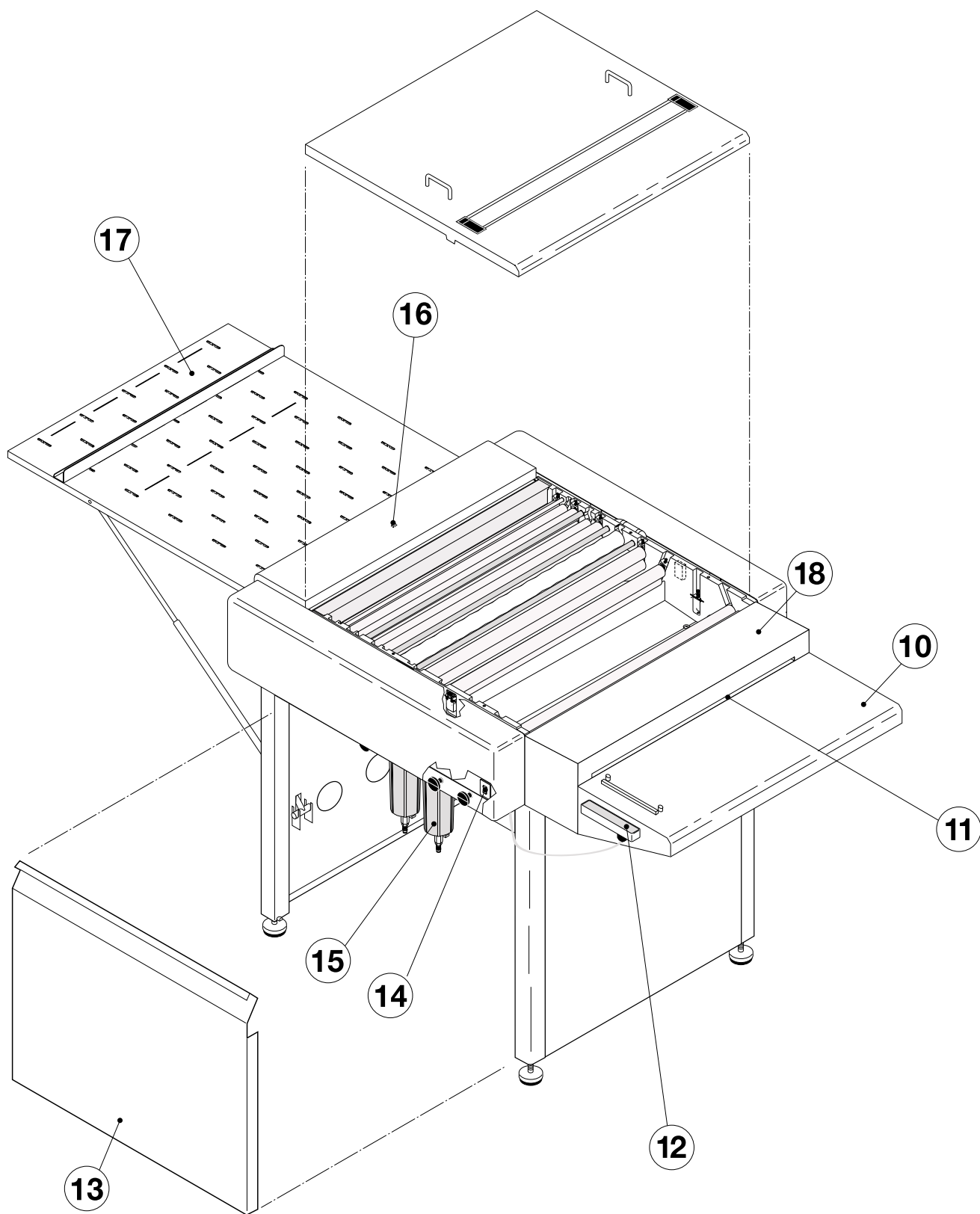

FEED TABLE (10)**(Only off-line processors)**

The plate is fed into the processor from the feed table. The feed table is equipped with a plate feed guide to ensure that the plate is fed straight into the processor.

INPUT SENSORS (11)

Activating the input sensors located in the plate feed entrance automatically starts the processor.

A counter function counts every activation of the input sensors and makes it possible to check the number of jobs processed in the machine.

The input sensor in the left side of the feed entrance is for off-line processors only.

CONTROL BOX (12)

The processor is operated from the Control Box. See detailed description of the various functions in chapter 3 later in this manual.

STAND PANELS (13)

The left and right panels of the stand can be removed to enable the operator to change containers, change filter elements and to drain the developer- and wash-off sections etc.

MAIN SWITCH (14)

The main switch is placed at the front of the electronics drawer located through the upper left side of the stand.

FILTERS (15)

The wash-off solutions are continuously circulated through filters located underneath the processor:

Wash-off filters: 25 micron +3 micron

OUTPUT SENSOR (16)**(Only on-line processors)**

The output sensor placed at the dryer section exit helps to detect plate jam. If the output sensor is not activated within a preset time from when the input sensor(s) (11) was activated a plate jam may have occurred.

EXIT TABLE (17)**(Option)**

When processed the plate ends on the exit table. The telescopic supports underneath the table makes it possible to adjust the slope and the output bracket can be fitted in three (3) different positions to match the plate size.

PRE-PROCESS SECTION(18)

Refer to the description about the pre-process section later in this chapter.

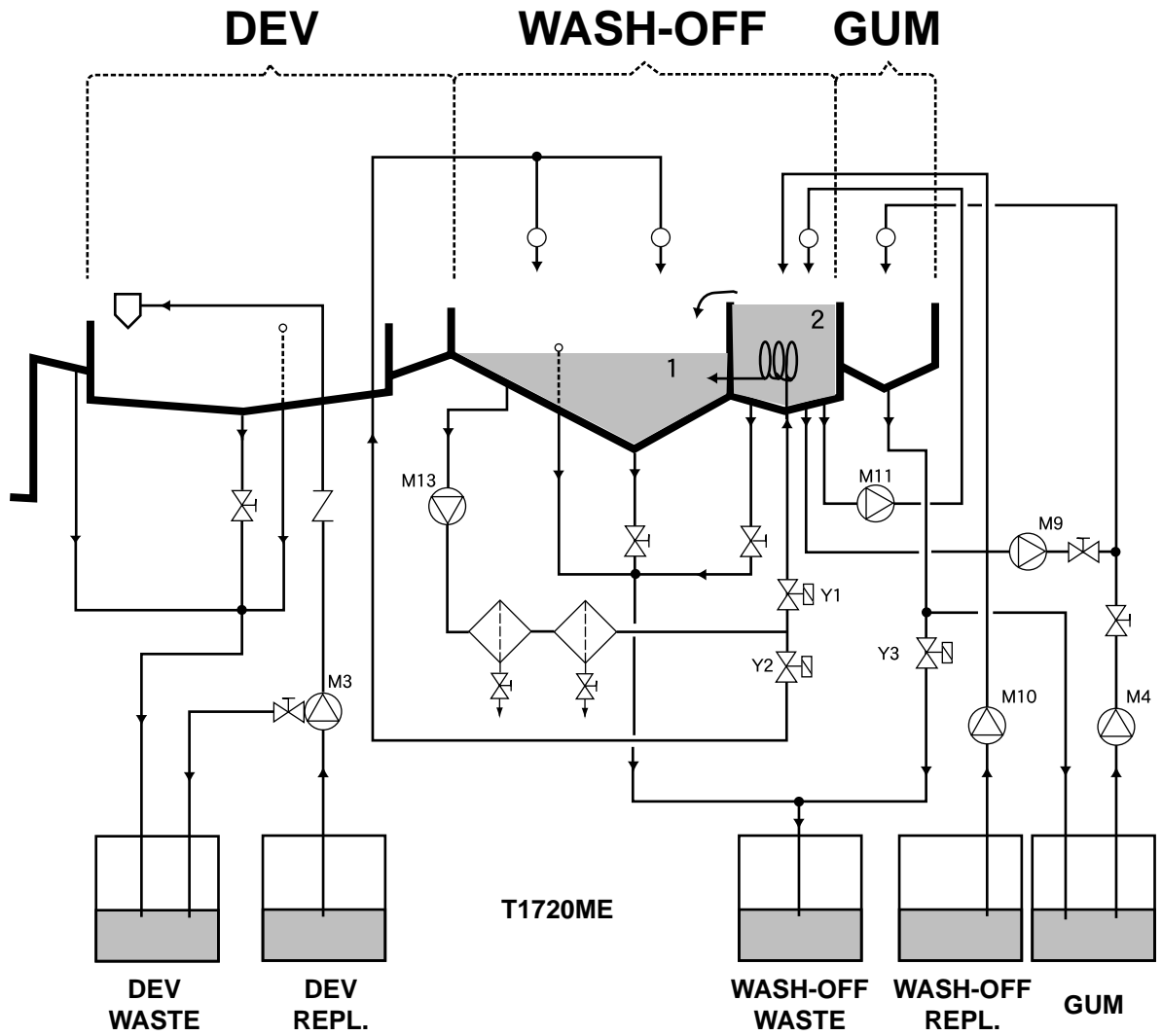

2-3.FUNCTIONAL DESCRIPTION

DEVELOPER SECTION

The previous page illustrates the flows of developer, wash-off, and gum section in the processor. The following are brief descriptions of each section in the processor.

(See the illustration on the opposite.)

General

Exposed plates are developed in the developer section.

DRAIN OF DEVELOPER

The drain valve underneath the developer tank is normally open, in order to drain developer used for plate development directly into the waste liquid tank as wastes.

DEVELOPER COATING SYSTEM

The diaphragm pump (M3), connected to the external developer replenishment tank, supplies developer to the coating bar which coats the plates. Once a plate is inserted, the sensor at the entrance of the processor activates the coating control circuit. The developer pump can also be operated from the EcoRF control panel.

TRANSPORT SYSTEM

(See the illustration below.)

Two pairs of transfer rollers are provided in the developer section.

The first roller pair (1) is situated outside the developer section to ensure even development.

The free transport rollers (2) act as intermediaries between the transport rollers.

The second roller pair (3) squeezes the residual developer off the plate before the plate leaves the developer section and enters the wash-off section.

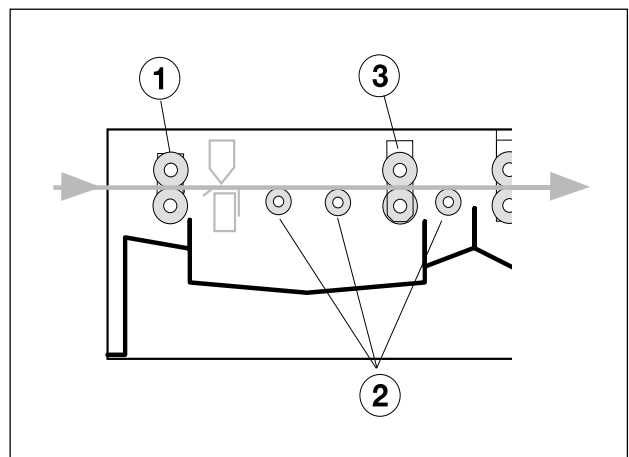

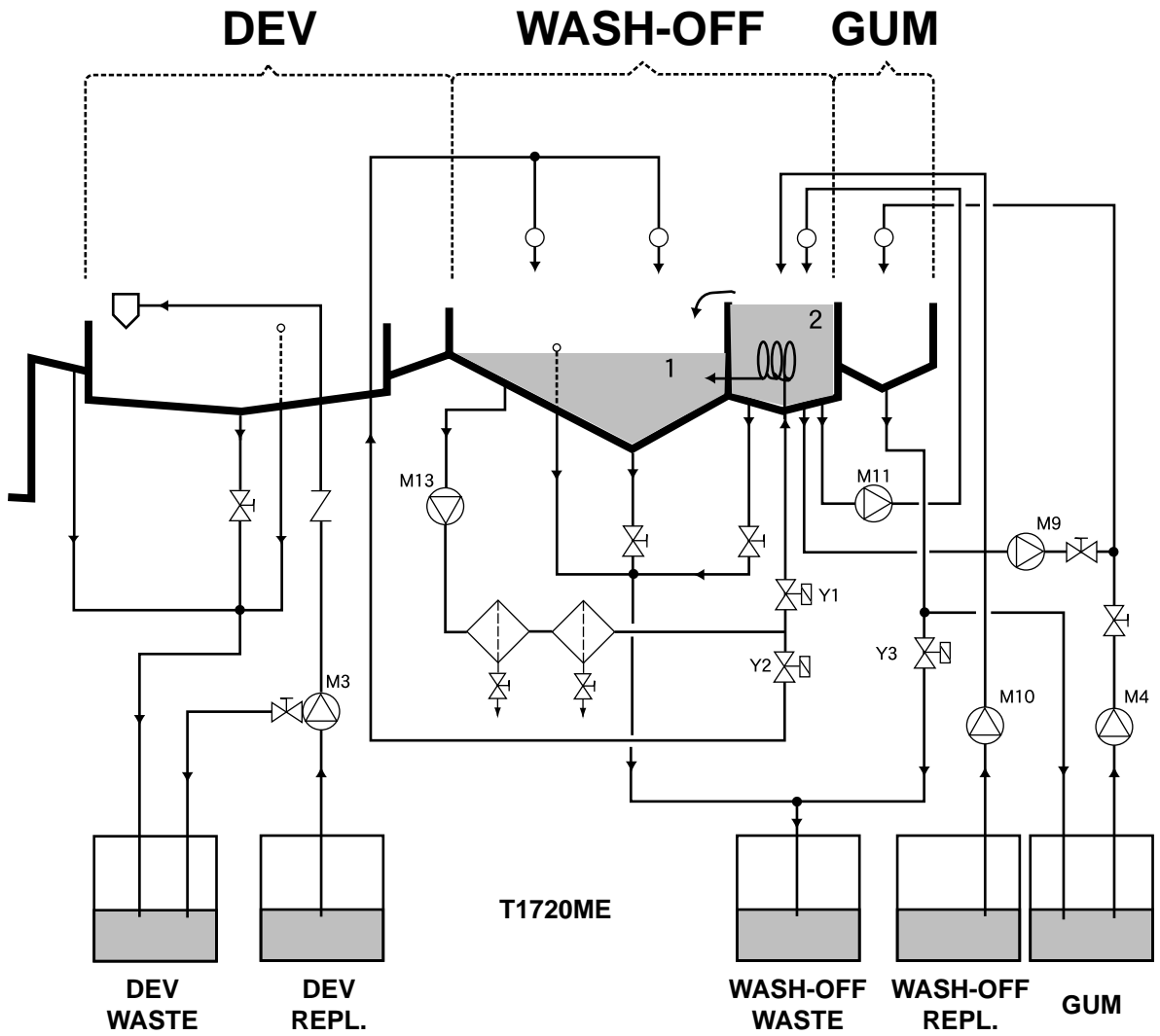

WASH-OFF 1 & 2 SECTIONS

(See illustration opposite).

GENERAL

The WASH-OFF section is separated in two sections: WASH-OFF 1 and WASH-OFF 2

In WASH-OFF1 the gelatine layer and the exposed silver is washed / brushed off the plate and in WASH-OFF2 the plate is exposed to the action of fresh wash-off solution.

TEMPERATURE CONTROL

A heating element and a temperature sensor in WASH-OFF 1 make sure that the solution temperature setting is kept constant.

LEVEL CONTROL

A level detector in WASH-OFF 1 prevents operation of the processor with insufficient amount of solution in the tank.

CIRCULATION SYSTEM/FILTERS

The circulation pumps (M13) recirculates the wash-off solution to maintain a uniform temperature. Two solenoid valves (Y1, Y2) control if the solution in WASH-OFF 1 is circulated through a heating coil in WASH-OFF 2 (STANDBY) or if the solution is circulated through the two spray tubes (process).

The pump (M11) circulates the WASH-OFF 2 solution through a spray tube when in process. It also circulates while WASH-OFF 1 is heating up until temperature is app. 1°C below set-point.

When the wash-off solution circulates it passes through 2 filters that clean it. The wash-off filters are equipped with a pressure switch (P) which indicates if the 3 micron filter is blocked

The waste wash-off solution leaves the WASH-OFF 1 tank through an overflow opening in the tank wall. Both of the wash-off sections can be drained by opening the drain valves underneath the tank.

REPLENISHMENT SYSTEM

A bellows pump (M10) connected to an external replenishment container automatically adds fresh wash-off solution to the WASH-OFF2 section to compensate for solution used during plate processing. It also supplies additional solution to compensate for lost activity caused by oxidation. The fresh solution from WASH-OFF 2 overflows the tank wall into WASH-OFF 1 when replenishing. Sensors at the entrance of the processor start the replenishment control circuit when a plate is entered.

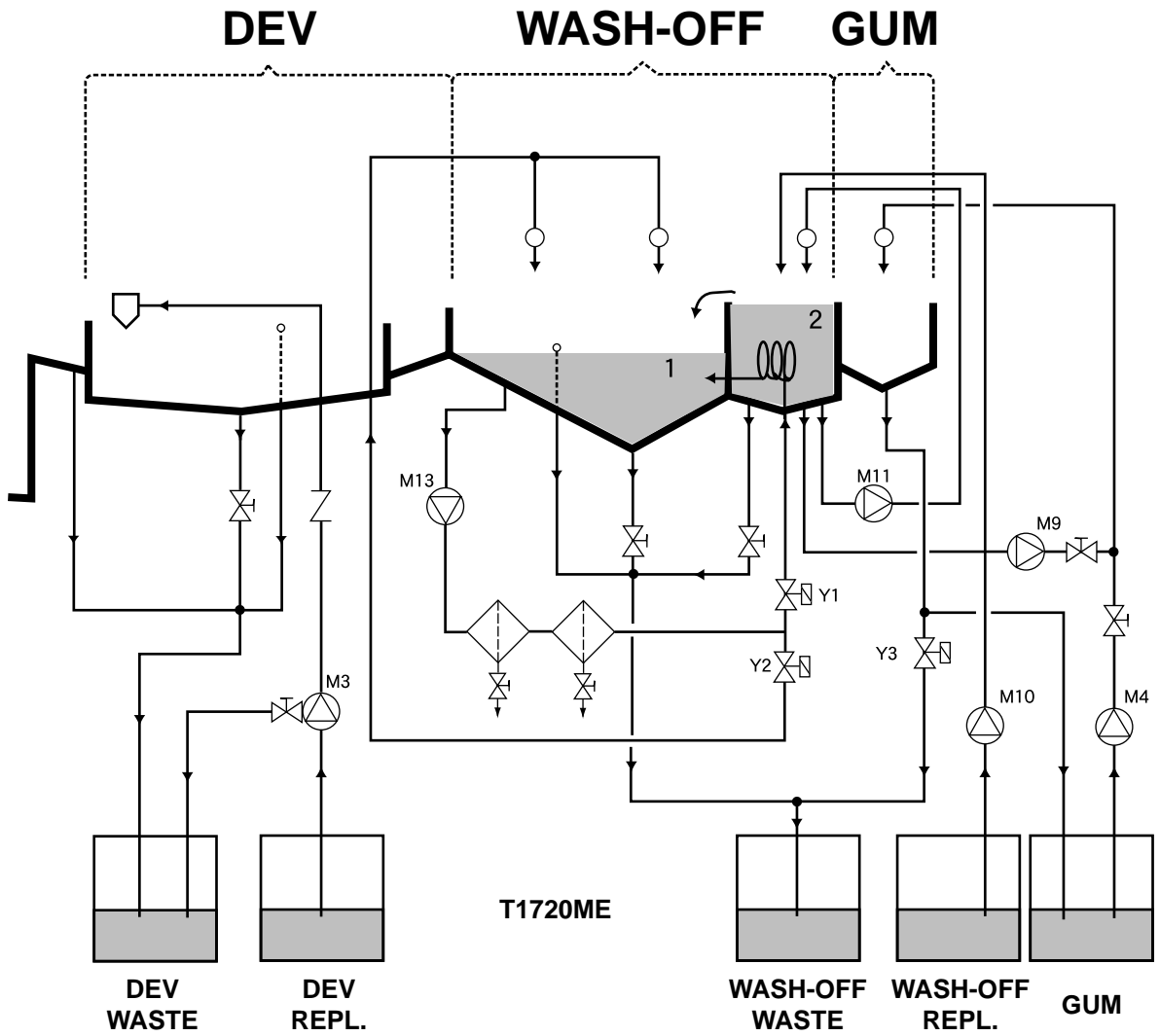

TRANSPORT SYSTEM

(See illustration to the right).

The WASH-OFF 1 section is equipped with two pairs of transport rollers. The first roller pair (5) leads the plate underneath the brush (6) and the spray tubes (7) and (8). The guide (9) is spring loaded ensuring a uniform brush pressure on the plate as well as it compensates for brush wear. The exit roller pair (10) squeezes the plate before it enters the WASH-OFF 2 section. The stop roller (11) in the WASH-OFF 2 section prevents that the solution applied on the plate from the spray tube (12) runs back into the WASH-OFF 1 section.

The roller pair (13) squeezes the wash-off solution off the plate before it leaves the section.

NOTE! Always lead waste wash-off solution to a waste container and not into a drain.

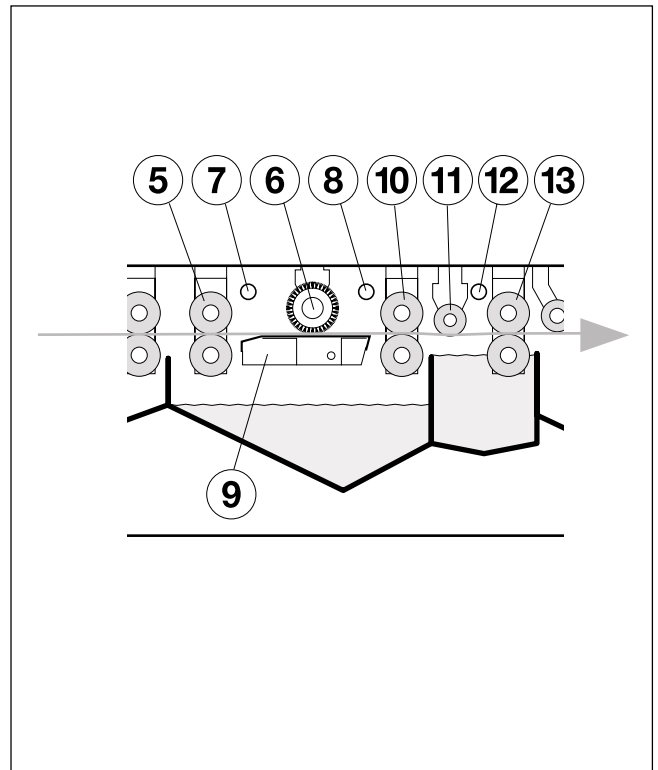

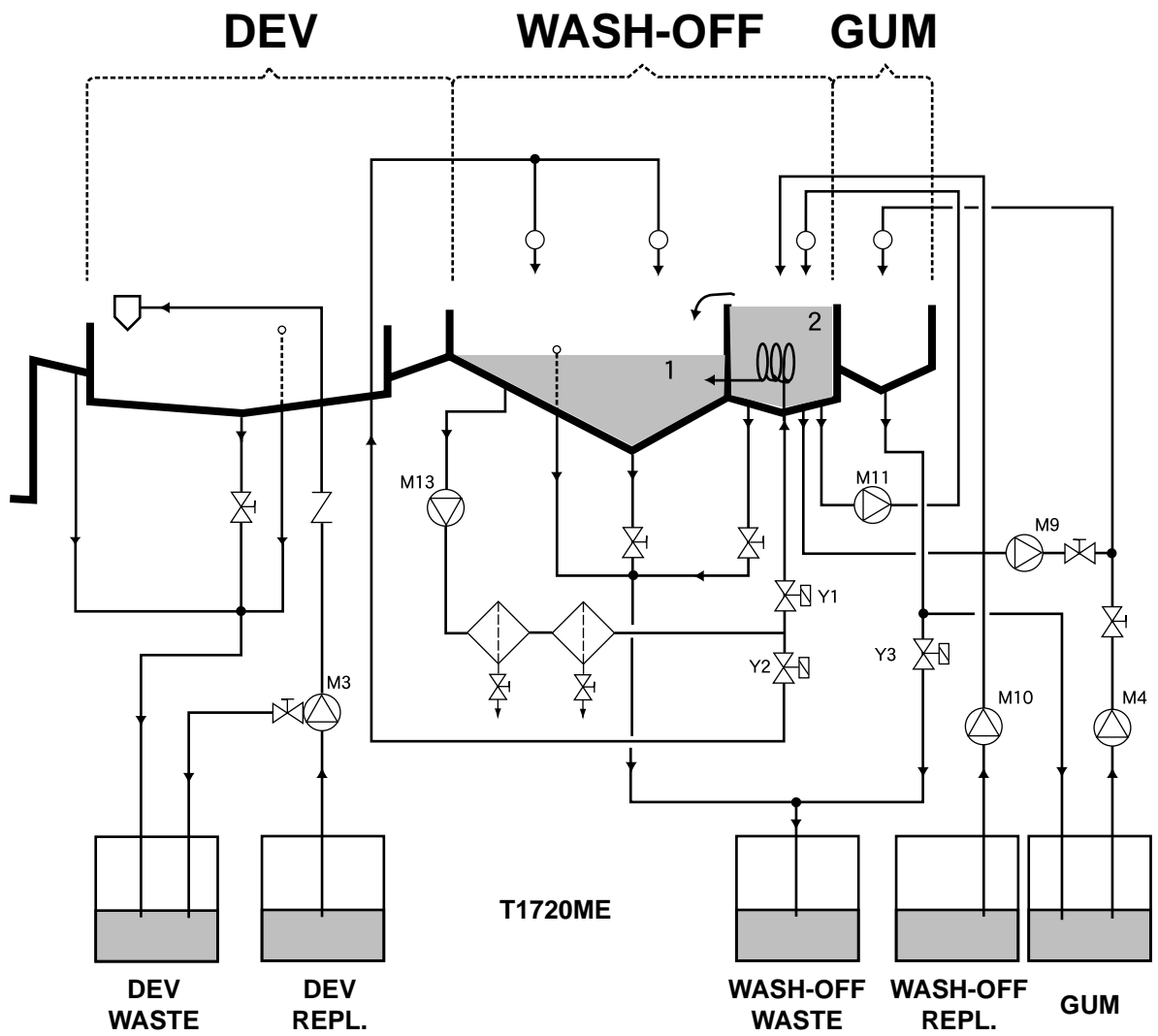

GUM SECTION

(See illustration opposite).

GENERAL

In the GUM section a thin layer of gum is applied to the developed and washed-off plate to protect it from dirt, finger prints etc. Later, when the plate is fixed in the printing machine, the layer will be rinsed off.

CIRCULATION

An oscillating pump (M4) pumps the gum from a container into a distributing tube and a valve enables adjustment of the gum flow. The gum tank, pump and gum container are connected in a closed system, so the gum runs back from the tank into the container and keeps recycling.

TRANSPORT SYSTEM

(See illustration below).

The gum section contains one rubber roller pair (14) and a smaller roller (15) situated close to the upper roller. The gum from the gum tube (16) forms a small bath between these two rollers and a thin coat of gum is applied to the plate while the extra gum is forced backwards.

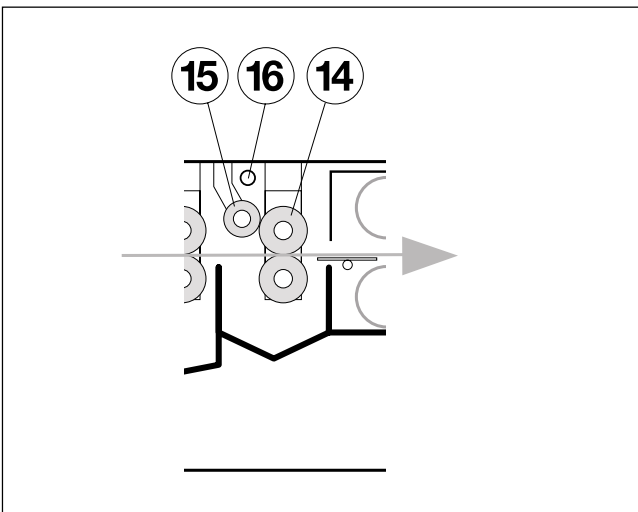

GUM-RINSE PROGRAM

The processor features an automatic gum-rinse program which cleans the gum distributing tube and the rollers of the gum section using the solution from the WASHOFF 2 section. A button for starting this program is on the control box (see chapter 5).

NOTE! The rinse program must be performed once a day only.

The rinse program works by means of an oscillating pump (M9) and a solenoid valve (Y3). The pump pumps wash-off solution from the WASHOFF 2 section through the gum tube and onto the gum rollers which turn slowly. The solenoid valve sees to it that the solution runs into the wash-off waste container and not into the gum container when leaving the gum section. When the rinse program has finished, the processor adds fresh solution to the WASHOFF 2 section to compensate for the amount expended on the rinsing and then it automatically shuts down.

DRYER SECTION

GENERAL

In the dryer section the plate is dried, and so further handling of the plate is possible immediately after it exits the processor.

AIR CIRCULATION TRANSPORT SYSTEM

A centrifugal fan with a built-in heater blows hot air through a manifold into two pipes(17) which dries the plate on both sides .

The system recirculates a volume of hot air, and at the same time it takes in some fresh air from outside of the processor. A thermostat keeps the drying temperature in range.

The single roller pair(18) in the dryer section leads the plate safely out of the processor.

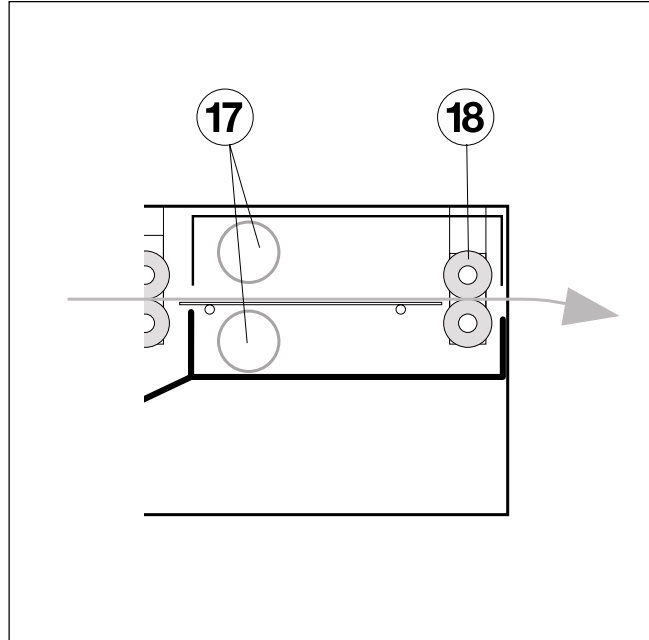

PRE-PROCESS SECTION

GENERAL

The pre-process section performs thermal processing to the plates inserted into the processor to enhance normal completion of the following development.

TRANSPORT SYSTEM

The pre-process section includes a pair of rollers (19), through which the plates are properly transferred into the processor.

The free shaft with the rollers (20) presses the plate to the heater to make the thermal processing uniform on the plate.

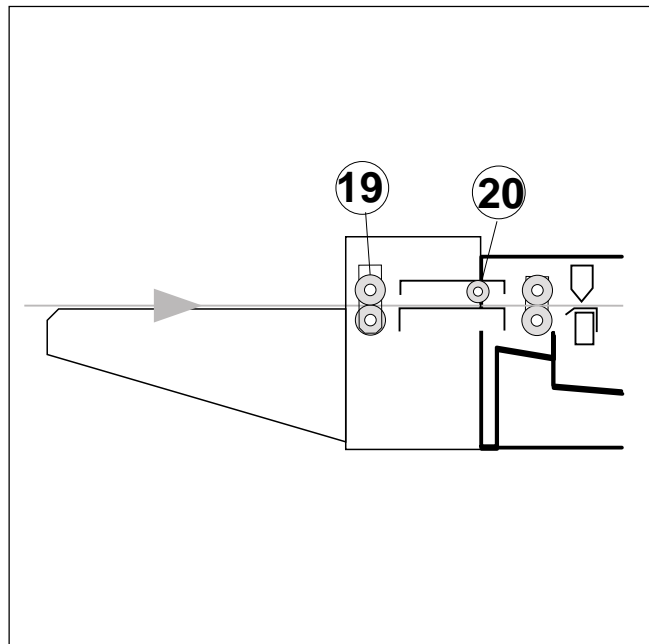

3. CONTROLS AND INDICATORS

3-1. THE CONTROL BOX

The operation of the processor is controlled from the Control Box (see illustration below).

The functions of the Control Box lamps and buttons are described on the next pages.

The Control Box holds buttons and indicator lamps for all the main processor functions, buttons for setting of the various speeds and temperatures of the system, and a display showing the set values.

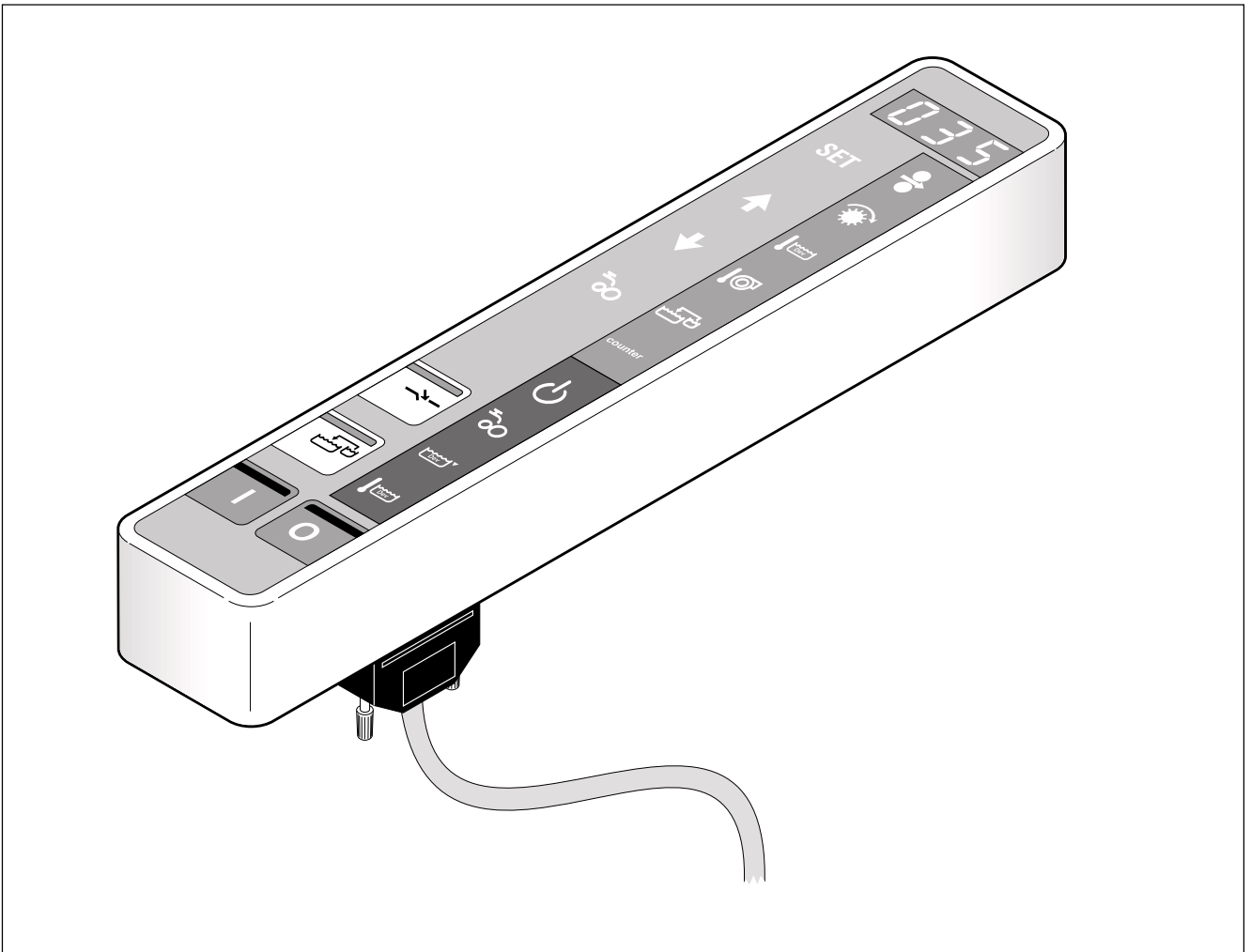

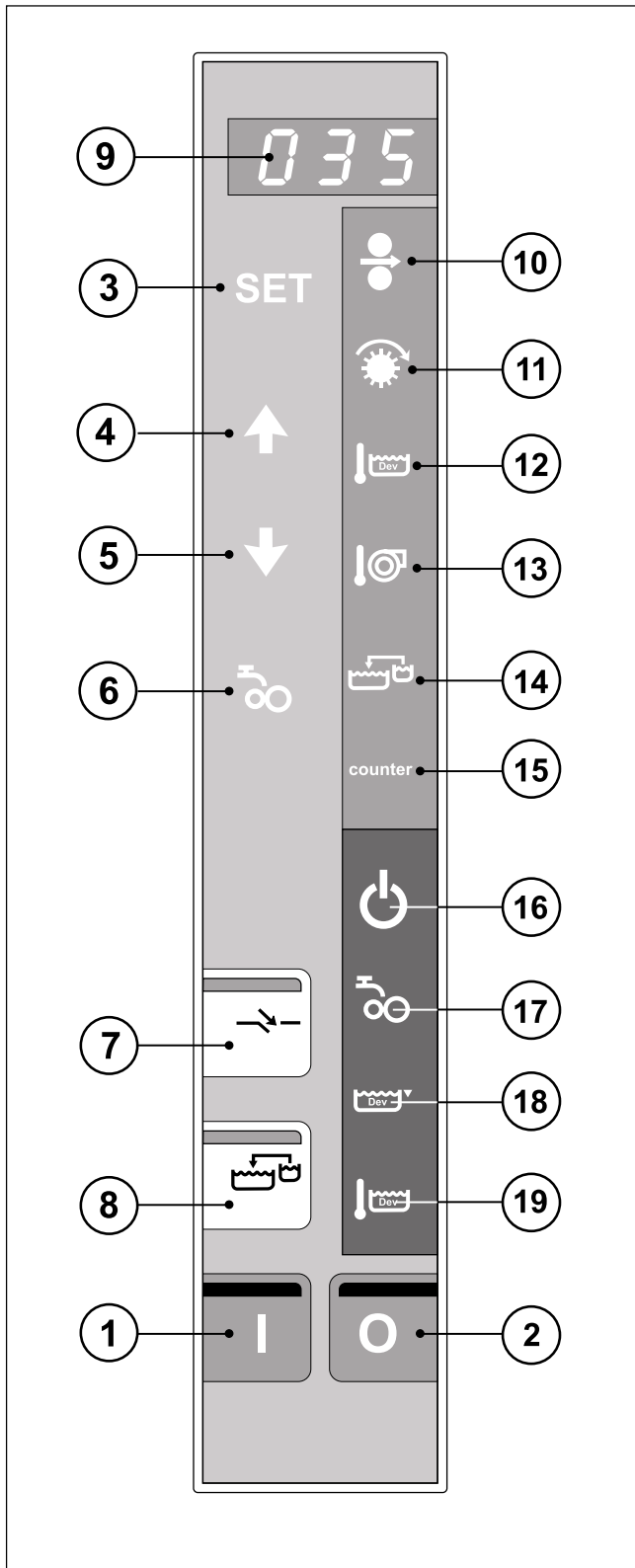

CONTROL PANEL LIGHT

All light in the display and various lamps of the control box (except for the light in the green on-lamp) can be switched off, when working in a darkroom with very light sensitive material. To switch off the light change value in parameter 02 to 0 (ask service engineer). If it becomes necessary to change a processing parameter, the display light will come on when pushing one of the "SET"-buttons (3). 20 secs. after the new setting has been confirmed the light will turn off again.

NOTE! Even though display light has been switched off all error codes will be displayed and "REWASH" lamp (7) will turn on if rewash is started.

FUNCTIONAL DESCRIPTION

ON-BUTTON (1)

(Lamp built-in).
Switches the processor from "OFF" mode into "STANDBY" mode provided that the main switch in the electronics drawer is switched on. When processor is in "STANDBY" or any other mode except for the "OFF" mode, the built-in lamp is lit.

OFF-BUTTON (2)

(Lamp built-in).
This button switches the machine from "STANDBY" mode into "OFF" mode. When the processor is in "OFF" mode only the built-in lamp is lit.

"SET" BUTTON (3)

Use "SET" button to

• **Change parameter values:**

The indicator for the selected processing parameter (10-15) is lit. Use the selection buttons (4) and (5) to select the processing parameter in which the value has to be changed. Push the "SET" button and the selected processing parameter indicator (10-15) will start to flash. Adjust the value using the selection buttons (4) and (5) and push the "SET" button again to confirm the new setting.

• **Reset the replenish container level function:**

See explanation for the "REPLENISHMENT" button (8).

SELECTION BUTTONS (4) & (5)

Use the selection buttons to

• **Select a processing parameter to be displayed or changed:**

The indicator for the selected processing parameter (10-15) will light up.

• **Change a processing parameter value:**

Use the buttons to increase or decrease the value.

See also description for "SET" button (3).

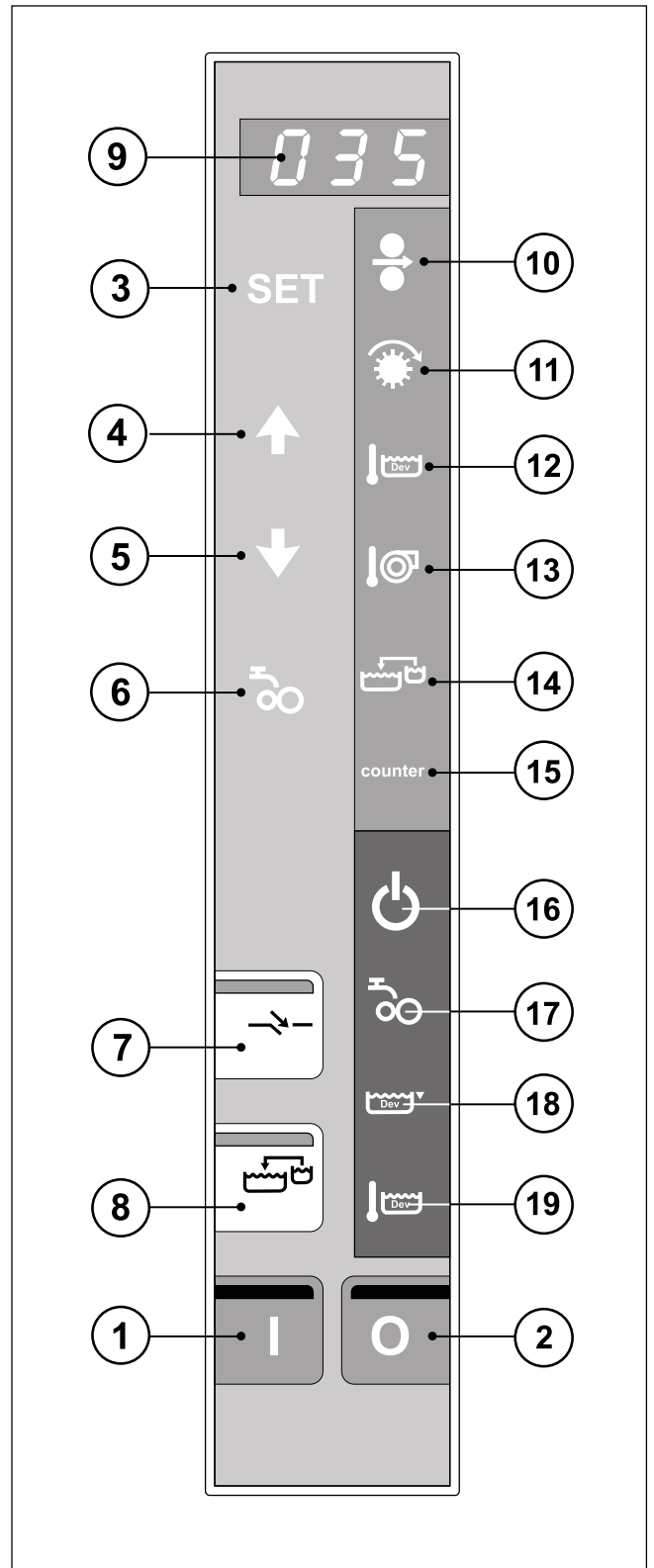

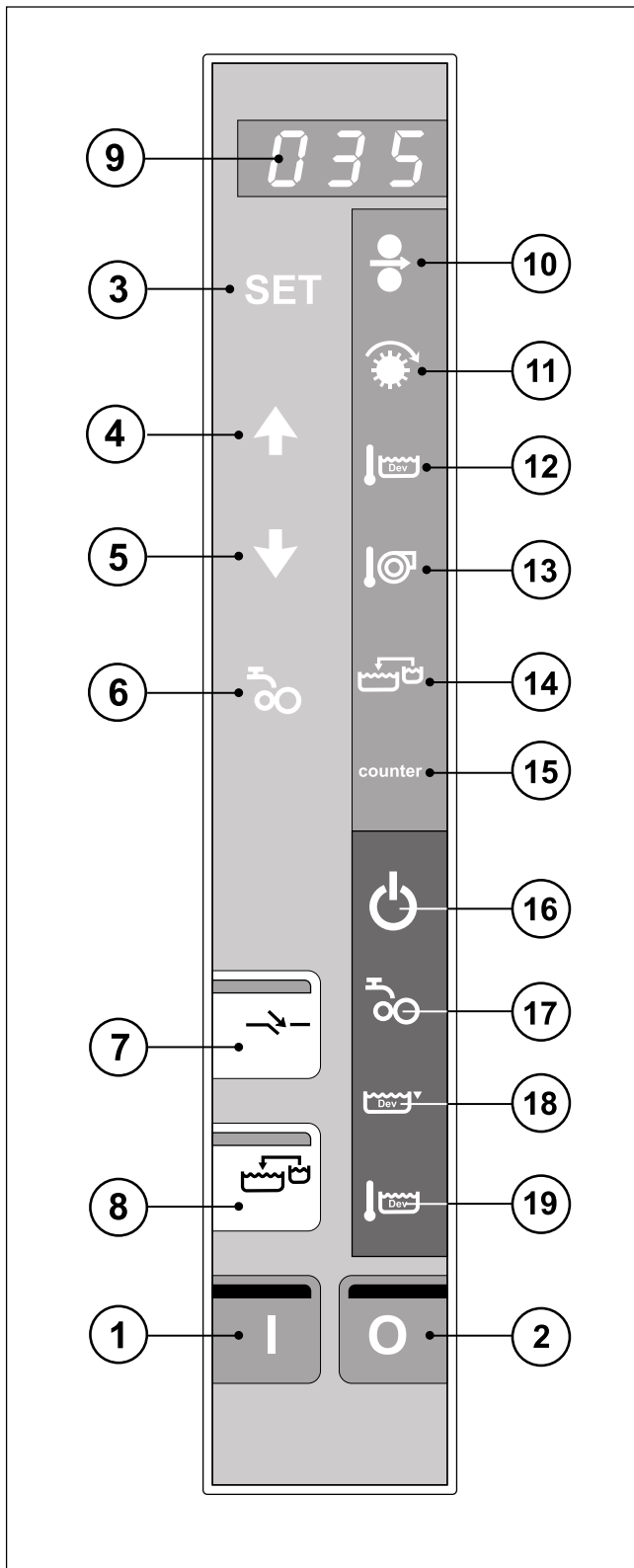

"GUM-RINSE" BUTTON (6)

Push the button and hold it for 3 secs. The "GUM-RINSE" program will start, the "GUM-RINSE" lamp (17) and the "WAIT" indicator (16) will start to flash asynchronously, which means that the "WAIT" indicator is on when the "GUM-RINSE" lamp is off and opposite. The rest of the control panel lamps and indicators are off except for the "ON" lamp (1). The display will show either "- A -" or "- O -" which are codes for the Auto-start function. See description of this function later in this chapter. When the rinsing part of the program is finished the "ON" lamp (1) turns off and the "OFF" lamp (2) starts to flash indicating that the gum section is being emptied. After a few minutes the processor automatically switches to "OFF" mode.

During gum-rinse when an input sensor is activated the transport mechanism stops to prevent that any material is fed into the processor.

"REWASH" BUTTON (7)

To start the "REWASH" function push the "REWASH" button twice. First push will stop the transport rollers and the built-in lamp will start to flash. Within the next 60 secs. the operator can carefully insert the plate into the "REWASH" slot. Second push will start all wash-off, gumming and dryer functions and the built-in lamp will be lit constantly together with the "WAIT" indicator (16). If the "REWASH" button is not pushed for the second time within the 60 secs. the processor will automatically return to "STANDBY" mode. The processor returns to "STANDBY" mode either automatically (time-out) after the plate has left it or manually when "REWASH" button is pushed for 2 secs.

NOTE! The above described procedure must be performed for each plate that is entered for rewashing and regumming. This is to reset the timer function.

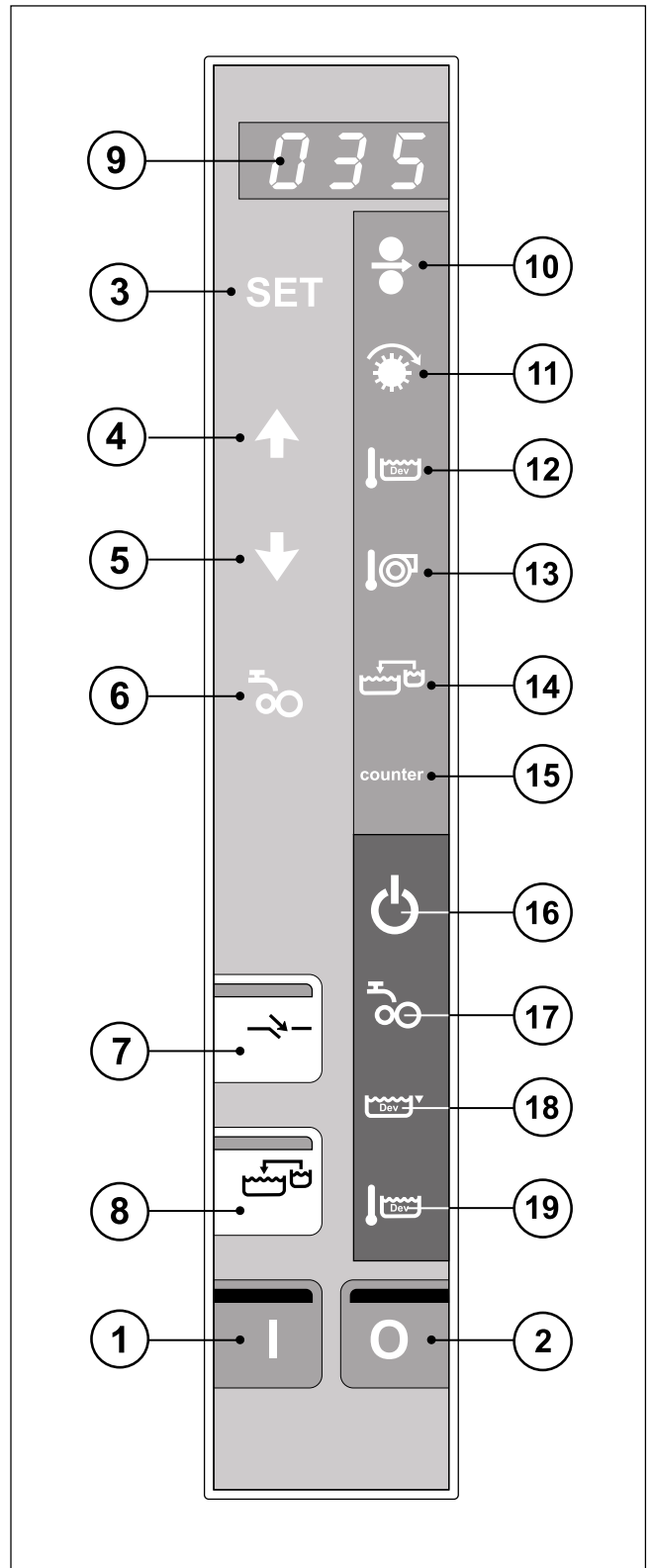

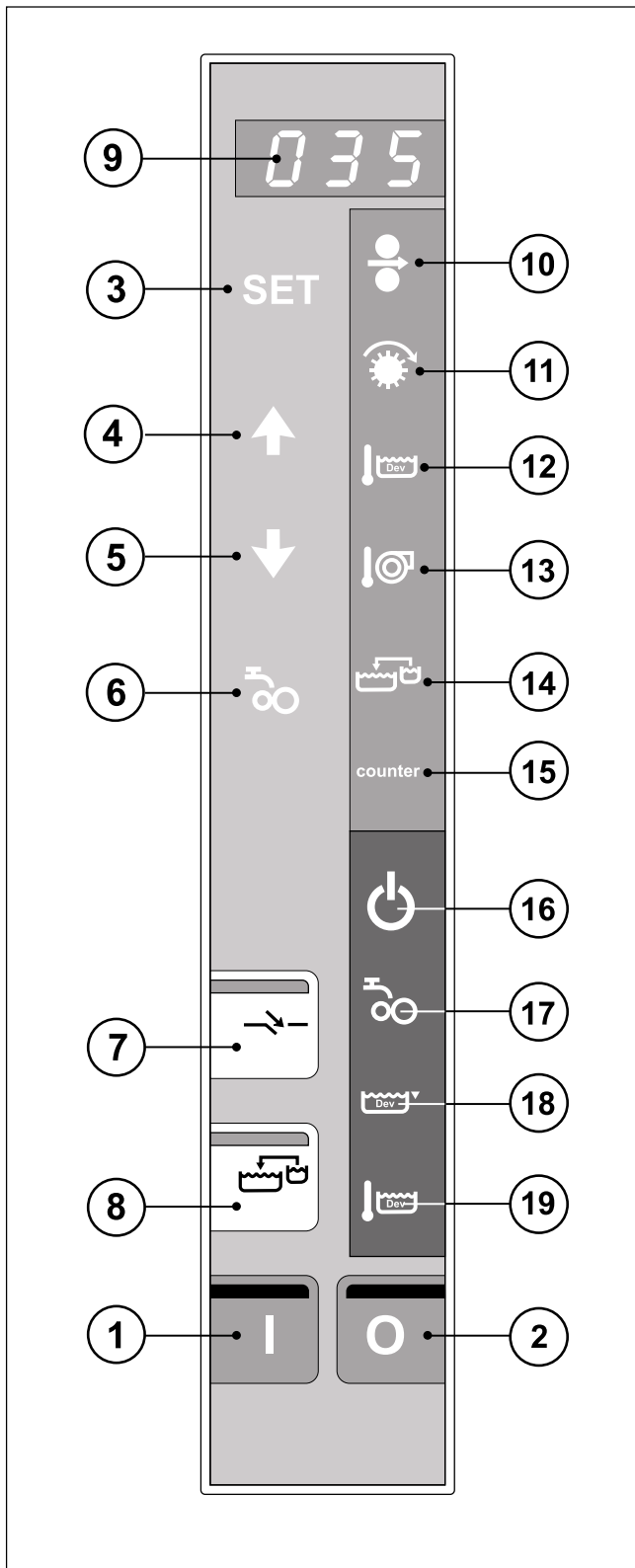

"REPLENISHMENT" BUTTON (8)

Use this button to

- **Manually top up the wash-off section with fresh solution:**

While the pump runs the built-in lamp in the button will be lit. If pumps have been started manually the pumps will stop again when pushing the button.

- **Reset the container level function:**

Push the "REPLENISHMENT" button (8) on the control panel and hold it for 3 secs.

The display will change to show either "1 _" or "1 -" indicating the status (empty/not empty) of the developer replenishment container.

Reset the container status to "1 -" (full) by pushing "SET" button (3) once.

If status is "1 -" before resetting, the display will change to "1 _" and then to "1 -" again to confirm resetting.

Push "REPLENISHMENT" button again and the display will change to show either "2 _" or "2 -" indicating the status (empty/not empty) of the wash-off replenishment container.

Reset the container status to "2 -" (full) by pushing "SET" button (3) once.

Push the "REPLENISHMENT" button (8) to exit the function.

If low level is detected in the wash-off sections the automatic replenishment system will automatically start the respective replenishment pump to re-establish the correct level. While the pump run the built-in lamp will be lit.

NOTE! If a section is empty, it should be filled from suitable containers as it is quite time-consuming to fill it using the pump.

DIGITAL DISPLAY (9)

The display will show

• **Values for the different functions:**

During process the display will always show the set value for the default processing parameter. If another function has been selected, the display returns to show the default processing parameter shortly after.

The default processing parameter is selected in set-up parameter 03 . (ask service engineer)

• **Error-codes/Auto-start codes:**

See detailed description later in this chapter.

PLATE SPEED (10)

Indicator for plate speed function.

When selected the displays shows the set plate speed in cm/min. (inch/min.).

BRUSH SPEED (11)

Indicator for brush speed function.

When selected the displays shows the set brush speed in rpm.

DEVELOPER TEMPERATURE (12)

Indicator for developer temperature function.

When selected the displays shows the set developer temperature in °C (°F). Shoud be input 25°C (77°F).

DRYER TEMPERATURE (13)

Indicator for dryer temperature function.

When selected the displays shows the set dryer temperature in °C (°F).

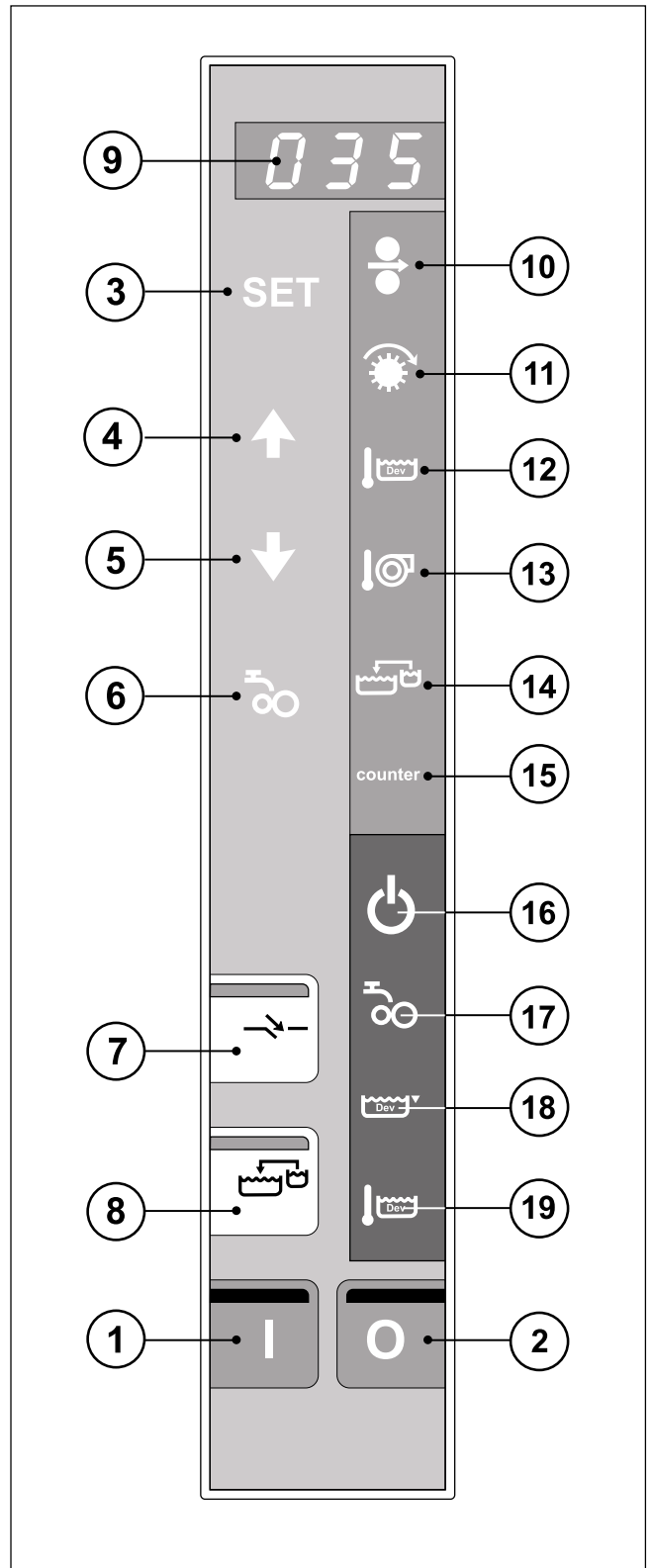

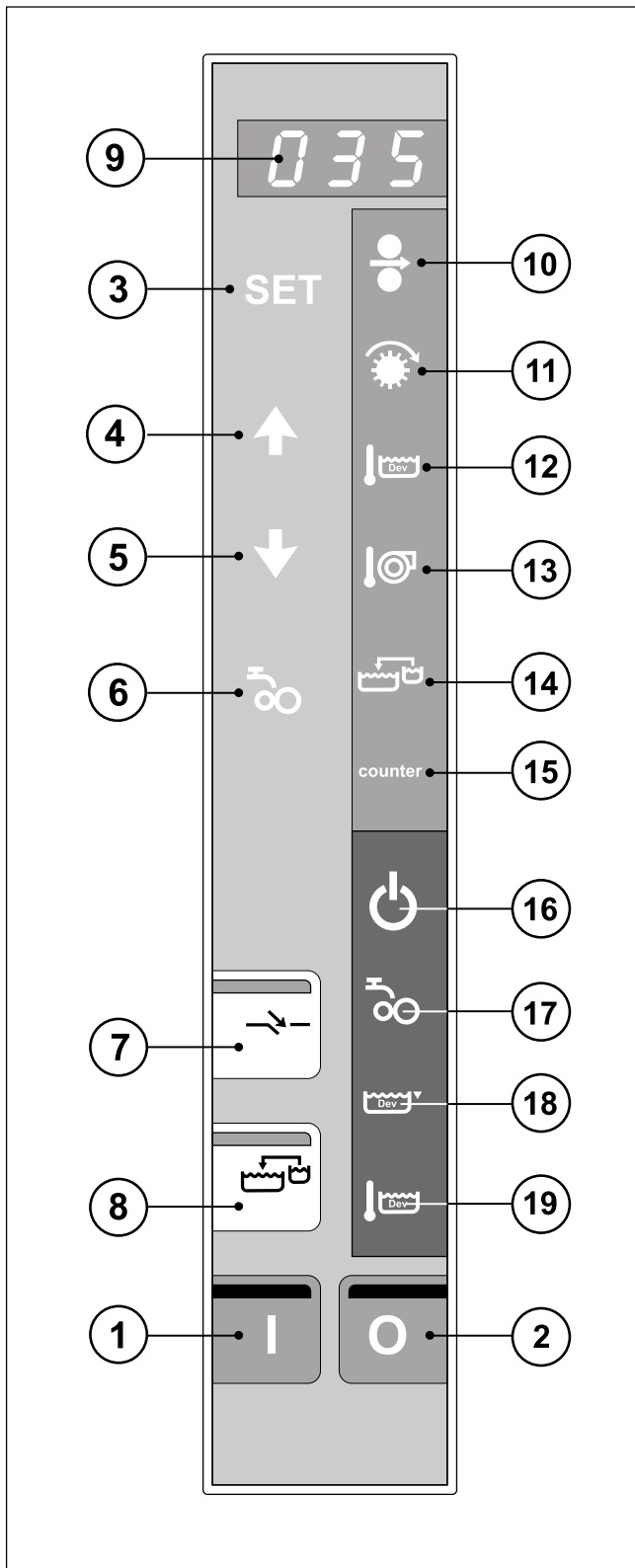

WASH-OFF REPLENISHMENT (14)

Indicator for the replenishment function.
When selected the display shows the set plate width in cm (inch).

COUNTER (15)

The counter function makes it possible to check the number of jobs processed in the machine, as it counts every activation of the input sensor(s).
The "SET" button (3) resets the counter, but only when the counter function has been selected using the SELECTION buttons (4 &5)(indicator lit).

"WAIT" (16)

This indicator is lit if any of the following situations occur:

- Replenishment container error.
Also a beeper will sound for 10 secs. and the display will show “- 2 -”.
- PRE-PROCESS temperature out of range.
The display will show “- 3 -”.
- DEV temperature out of range.
Also the “DEV. TEMP.” indicator (19) will be lit.
The display will show “- 4 -”.
- Low level in WASH-OFF 1 section.
The display will show “- 5 -”.
- WASH-OFF 1 temperature out of range.
The display will show “- 6 -”.
- WASH-OFF filters blocked.
The display will show “- 7 -” and a beeper will sound.
- Processor in “REWASH” mode.
The “REWASH” lamp (7) will also be lit.
- Input sensor(s) activated.
and it **flashes** (asynchronously with "GUM-RINSE" lamp (17) when processor is in “GUM-RINSE” mode.)
- Processor runs in “GUM-RINSE” mode.

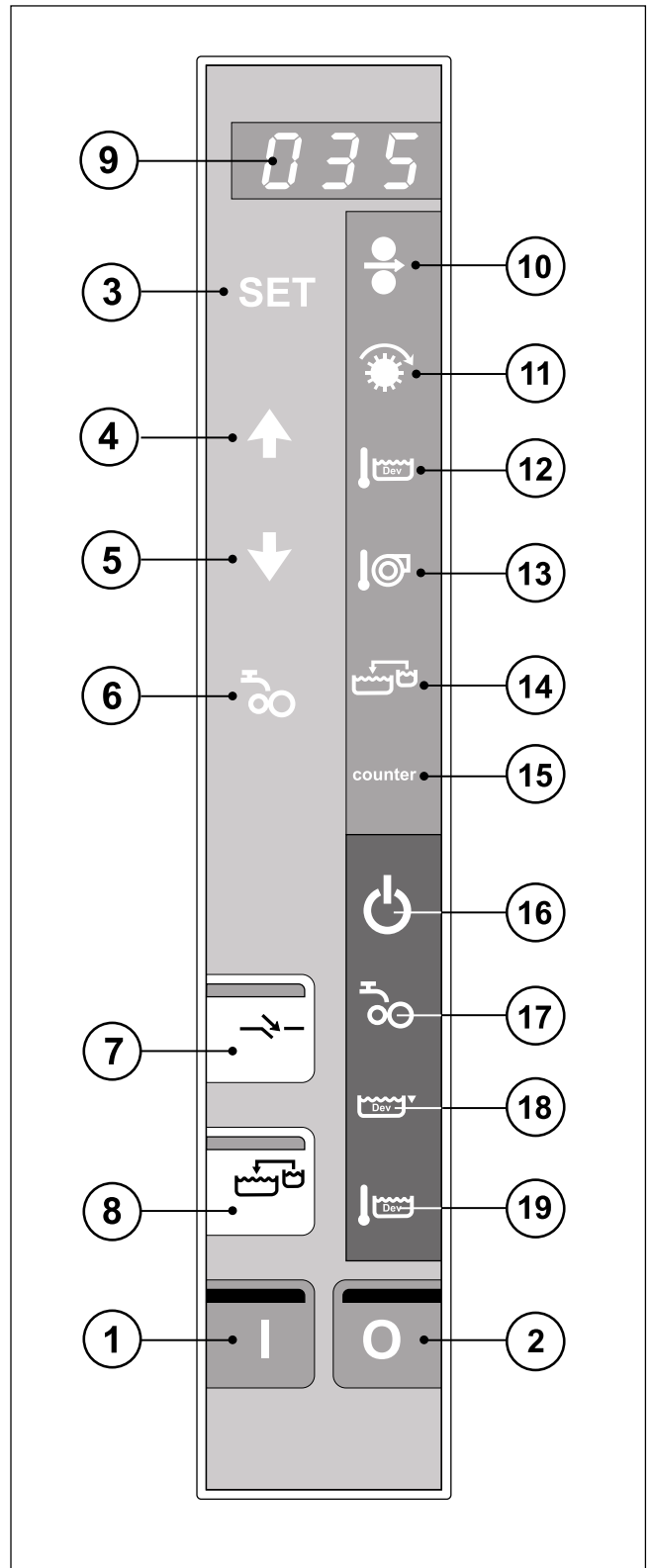

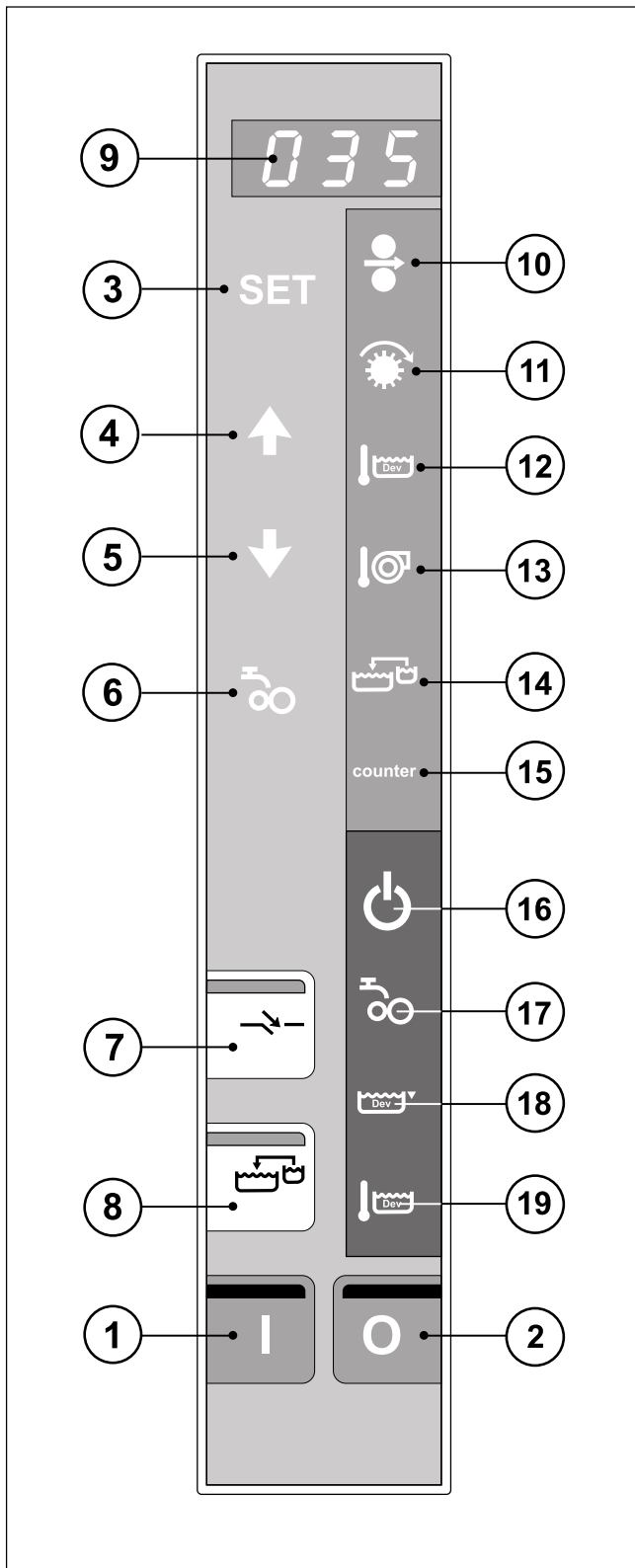

"GUM RINSE" (17)

This indicator flashes (asynchronously with "WAIT" indicator (16)) when processor is in "GUM-RINSE" mode.

"LOW LEVEL" (18)

If low level is detected in the developer bath, this indicator is lit.

Now, this function does not use.

If the error appear display, call service engineer.

"DEV. TEMP." (19)

This indicator lamp is lit if the temperature in the developer bath is out of range; 'out of range' means that the actual temperature in the bath is ex. 5°C higher or lower than the preset value.

ERROR/AUTO-START CODES

Various codes can be displayed on the control panel display (9):

ERROR CODES:

- **1 - Tacho error on transport motor.**
Will appear for 5 secs. at each input sensor activation.
- **2 - Replenishment container error.**
Also a beeper sounds for 10 secs. and "WAIT" indicator (16) is lit.
- **3 - PRE-PROCESS section temperature out of range.**
"LOW LEVEL" indicator (18) and "WAIT" indicator (16) are lit.
- **4 - Developer temp. out of range.**
"DEV. TEMP." indicator (19) and "WAIT" indicator (16) are also lit.
- **5 - Low level, WASH-OFF 1 section.**
"WAIT" indicator (16) is lit.
- **6 - WASH-OFF temp. out of range.**
"WAIT" indicator (16) is lit.
- **7 - WASH-OFF circulation filters blocked.**
"WAIT" indicator (16) is lit and a beeper will sound.
Will appear for 10 secs. at the start of each processing cycle.
- **8 - Plate jam error.**
Only for on-line processors.

AUTO-START CODES:

- **A - Auto-start switched on.**
- **O - Auto-start switched off.**

See how to use the Auto-start function in chapter 4 - "SHUTDOWN PROCEDURE" later in this manual.

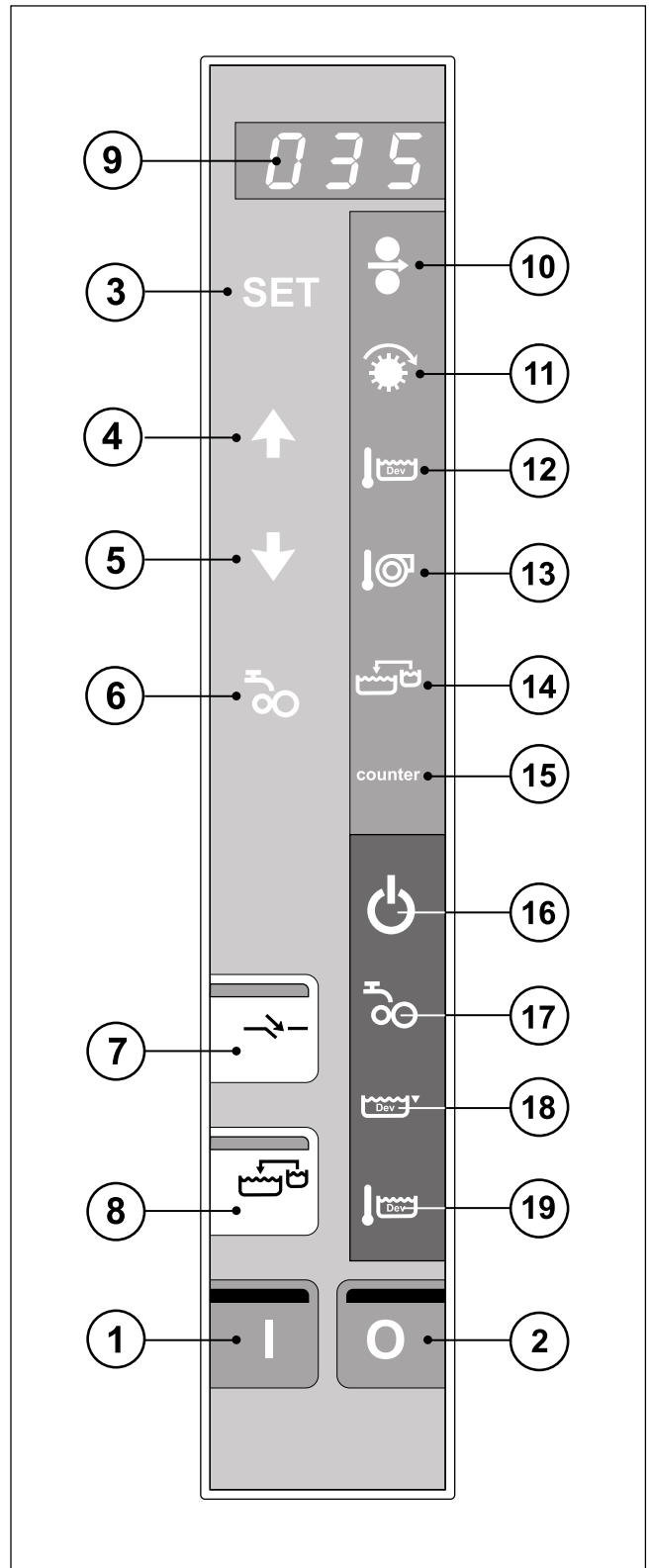

4. OPERATING PROCEDURES

On the following pages are described the operating procedures as well as the different adjusting procedures.

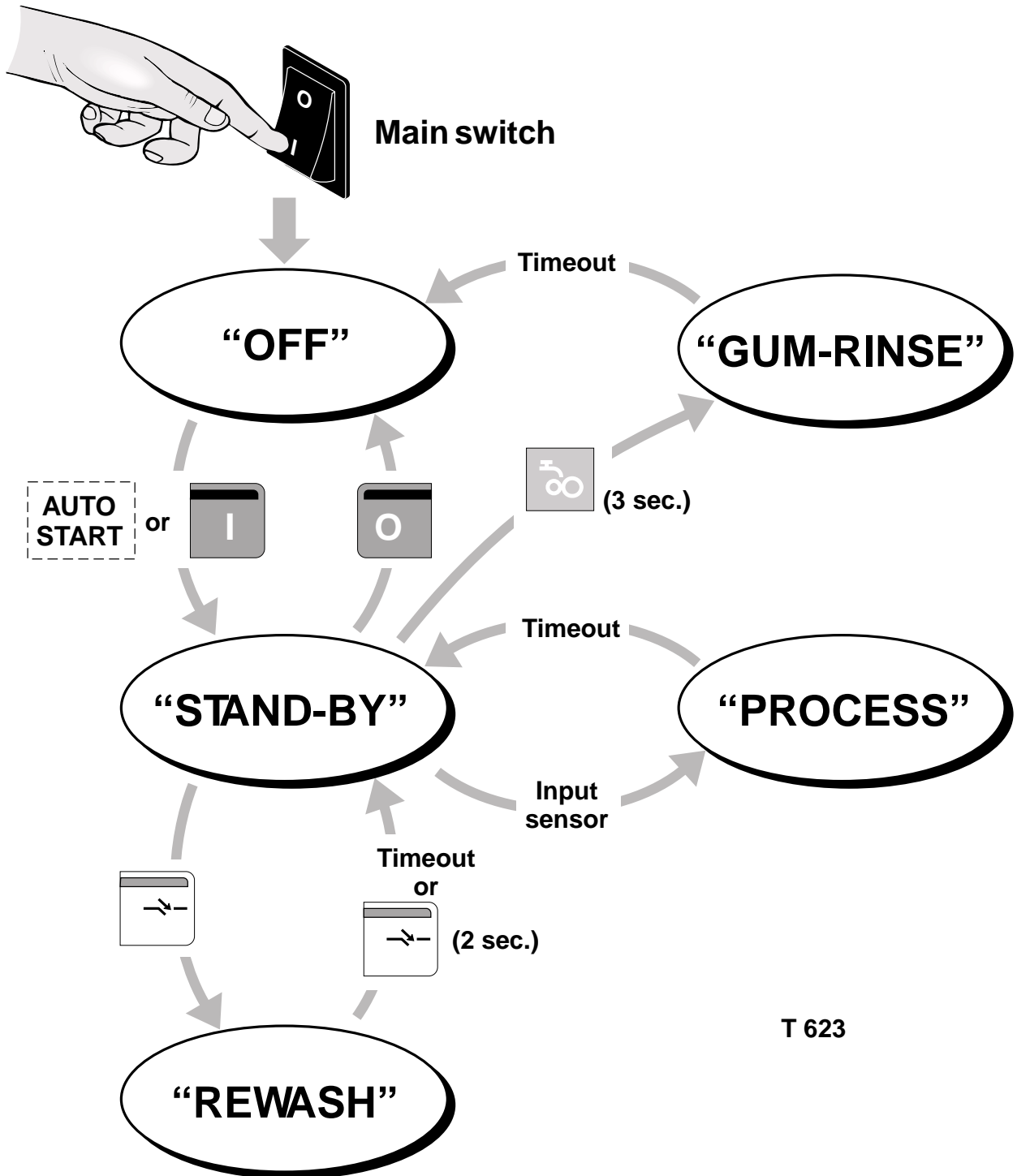

4-1. OPERATING MODES

(See illustration opposite).

The processor can be in one of 4 different modes **“OFF” mode**, **“STAND-BY” mode**, **“PROCESS” mode**, and **“GUM-RINSE” mode**.

Please refer to chapter 3 for more detailed descriptions of the various lamps and buttons mentioned in the following.

“OFF” MODE

When the main switch is switched on, the processor is automatically in **“OFF”** mode:

- Power is on to the processor.
- All functions are off.
- The lamp in the "OFF" button is lit.

“STAND-BY” MODE

Pushing the **“ON”** button switches the processor into **“STAND-BY”** mode:

- The lamp in the "ON" button is lit.
- Wash-off temperature control and circulation is on.
- Transport motor runs idle.
- All processing parameters are adjustable.

“PROCESS” MODE

Activating an input sensor makes the processor switch from **“STAND-BY”** mode into **“PROCESS”** mode (see also description in chapter 4 -**“PROCESSING FROM THE FEED TABLE”**):

- Transport motor switches to set transport speed.
- Dryer temperature control and blower is on.
- The brush and the various spray pumps start delayed just before the plate enters the respective sections.
- During processing the processing parameters are adjustable.
- The developer- and wash-off replenishment pumps adds replenishment to the sections as set in the specific parameters.
- The processor automatically returns to **“STAND-BY”** mode shortly after the plate exits.

“REWASH” MODE

(Only from **STAND-BY**).

(See also more detailed description in chapter 4-5 **USING THE REWASH SLOT**).

Pushing the **“REWASH”** button on the control panel twice switches the processor into **“REWASH”** mode:

- First push will stop the transport rollers. Within the next 60 secs. the operator must insert the plate into the **“REWASH”** slot.
- Second push will start all wash-off, gumming and dryer functions.
- The processor returns to **“STAND-BY”** mode either automatically (time-out) after the plate has left it or if **“REWASH”** button is pushed for 2 secs.

continues.....

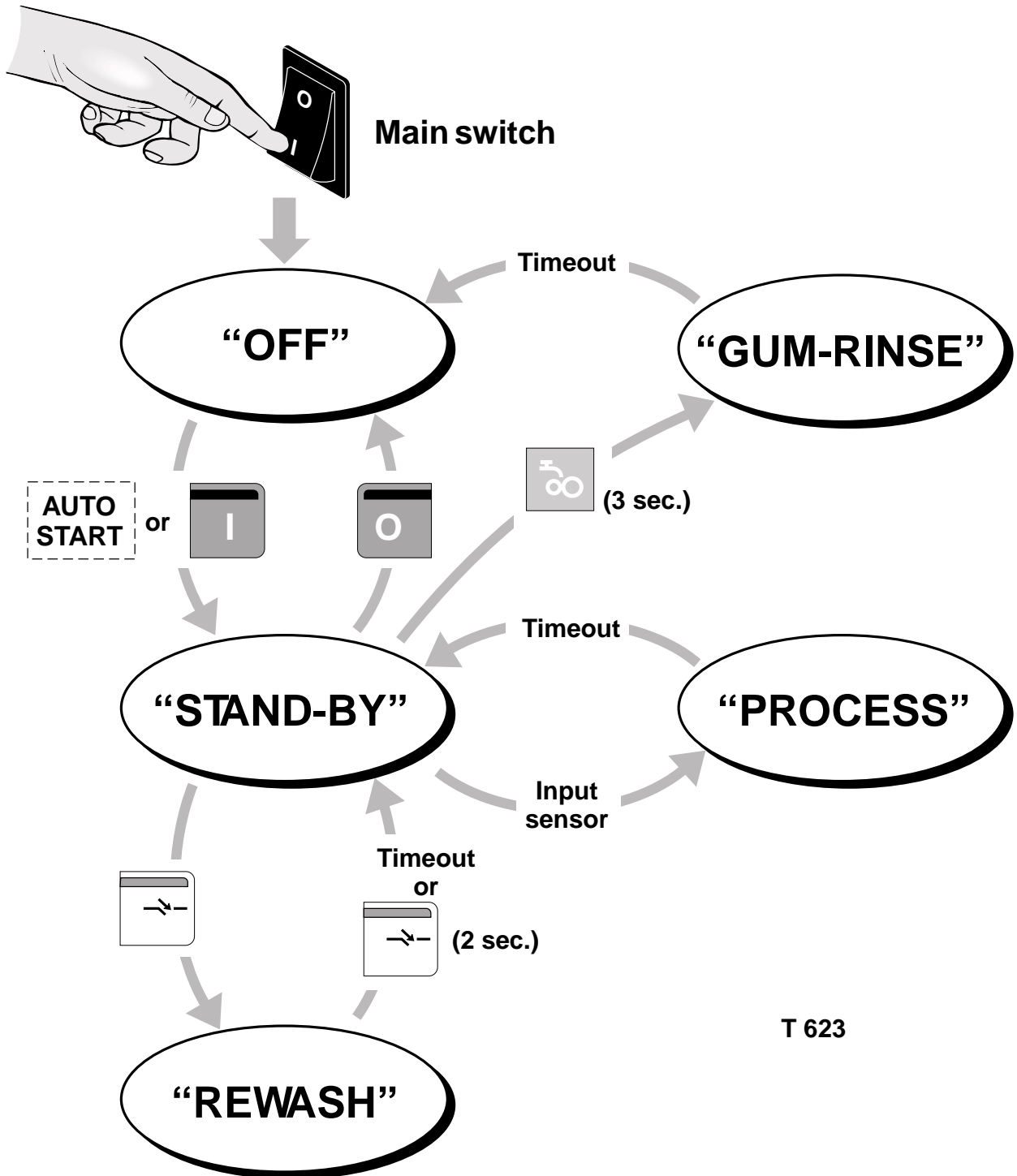

"GUM-RINSE" MODE

(Only from STAND-BY).

(See also more detailed description in chapter 5 - "RUNNING THE GUM-RINSE PROGRAM").

- Push the "GUM-RINSE" button for min. 3 secs. to start the "GUM-RINSE" program.
- During the rinse program the control panel cannot be used except for the "OFF" button.
- When the rinse program is finished the processor automatically switches to "OFF" mode.

AUTO-START

When the processor is turned off on the OFF-button or when starting the "GUM-RINSE" program it can be selected whether or not you want the processor to start-up automatically the next day.

(See how in "SHUTDOWN PROCEDURE" later in this chapter).

When selected the processor automatically switches from "OFF" mode into "STAND-BY" mode at a preset time.

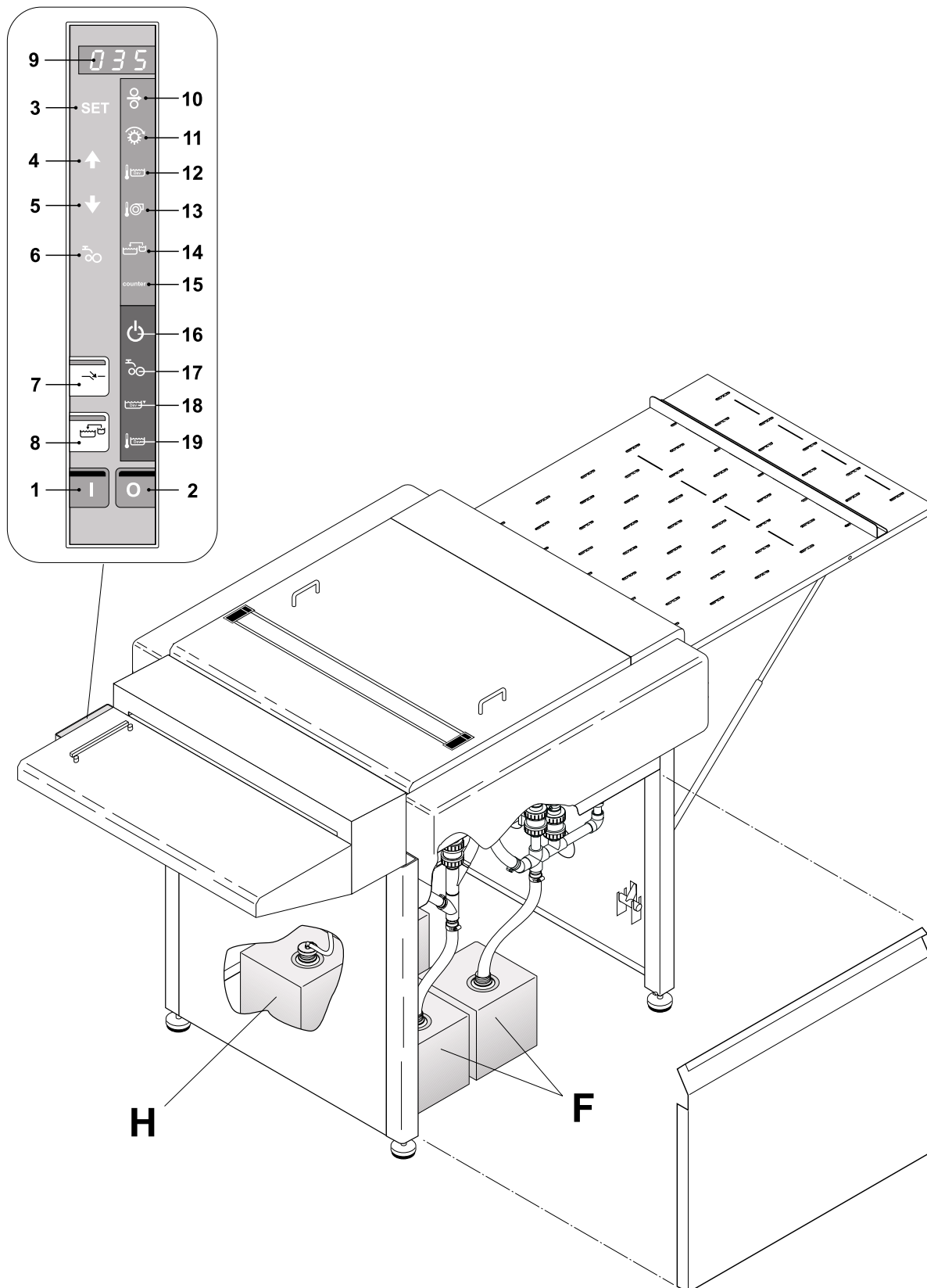

4-2. DAILY START-UP

(See illustration opposite).

NOTE! Before starting always make sure, that the containers for waste developer and wash-off solution (F) are empty.

NOTE! Check that the containers for developer and wash-off replenishment, gum (H) are sufficiently filled.

- If processor is not already started (AUTO-start) push the ON-button **(1)** and verify that the built-in lamp is lit.
The processor is now in "STAND-BY" mode with the rollers idling.
- Make appropriate processing parameter adjustments if necessary.
- The "WAIT" indicator **(16)** will be lit until all levels and temperatures are correctly established.
- When the "WAIT" indicator turns off, the processor is ready for use.

4-3. SETTING THE PROCESSING PARAMETERS

(See illustration opposite).

- Use selection buttons **(4)** and **(5)** to select the processing parameter(s) you want to change:

(10) Plate speed (105) (50 - 240cm/min)

(11) Brush speed (100) (40 - 120 rpm)

(12) Dev. temp. (25) (15 - 45 °C)

(13) Dryer temp. (60) (30 - 65 °C)

(14) Dev. Repl. (plate width) (0 - 88 cm)

(The first set of numbers are the standard settings).

The setting value for the Stabilizer Repl. **(14)** should be the width of the plate (in cm) to be processed. The processor measures the plate length when processing and then uses the set plate width to calculate the plate area.

- To change f.ex. the brush speed push selectionbutton **(4)** or **(5)** until "Brush speed" indicator **(11)** is lit.
The current setting is shown in the display **(9)**.
- Push "SET" button **(3)**.
The "Brush speed" indicator **(11)** will start to flash indicating that it is now possible to adjust the value.
- Use selection buttons **(4)** and **(5)** to change the value and then push "SET" button **(3)** to confirm the new setting.
- Repeat procedure for each parameter you want to change.

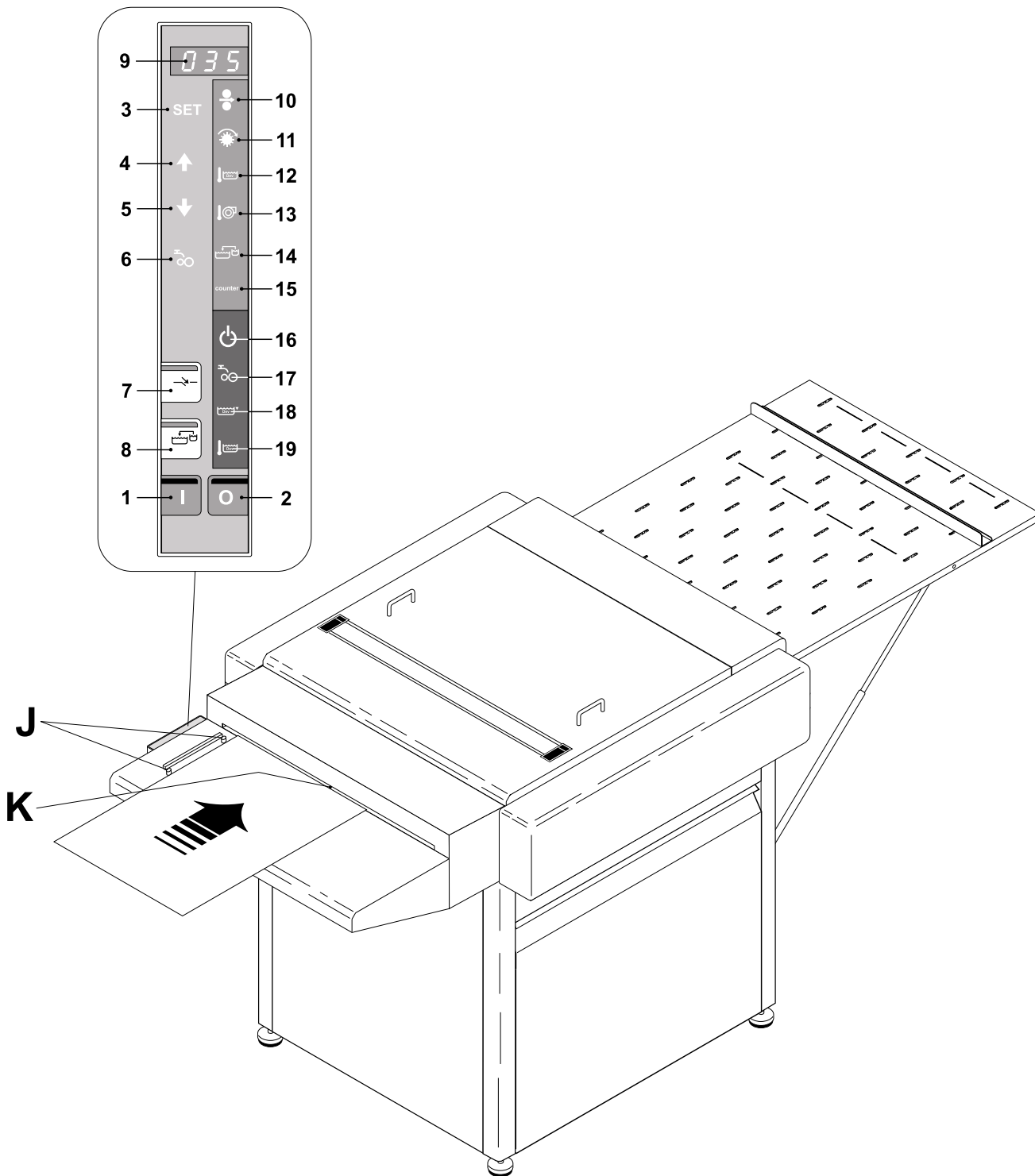

4-4. PROCESSING FROM THE FEED TABLE

Only off-line processors.

(See illustration opposite).

- The processor must be in "STAND-BY" mode.
- Always feed plate material from the middle of the feed table and along of metal guide(J) with the emulsion side upwards.
- Feed the plate slowly into the processor until it engages the entrance rollers.

The input sensor(s) **(K)** switch(es) the processor into "PROCESS" mode and the machine starts up with the preset speed and temperature values.

If control panel light is ON:

- Verify that the "WAIT" indicator **(16)** is lit, indicating that a plate is being fed into the machine.
- The "WAIT" indicator turns off shortly after the plate has left the input sensor(s).
A new plate can then be inserted.
- The machine returns to "STAND-BY" mode shortly after the plate has left the dryer section.

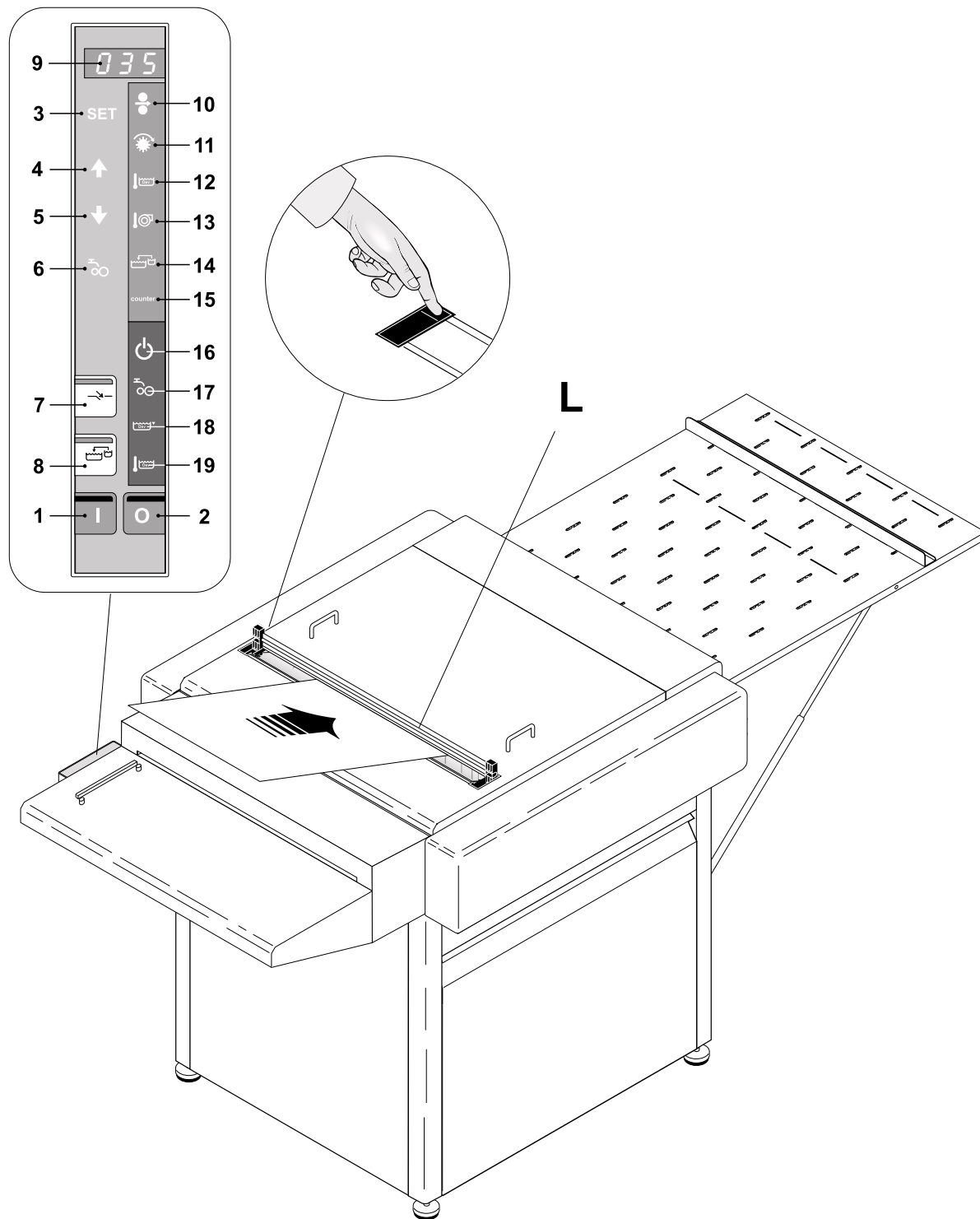

4-5. USING THE "REWASH" SLOT

(See illustration opposite).

- Machine must be in "STAND-BY" mode (switched on by the ON-button (1)).
- Open the "REWASH" lid (L) by pushing down as illustrated.
- Push the "REWASH" button (7).
The built-in lamp is lit, the "WAIT" indicator (16) will start to flash and if transport rollers run idle they stop.
- Insert the plate into the "REWASH" slot with the emulsion side upwards until it hits the transport rollers.
- Press the "REWASH" button (7) again.
The transport rollers start to turn and the wash-off, gum and dryer functions start while the developer functions remain in "STAND-BY".

NOTE! If "REWASH" button (3) is not pushed for the second time within 60 secs. the processor automatically returns to "STAND-BY" mode.

- When the plate has left the "REWASH" slot close the lid (L) again.

- The "REWASH" program ends (processor returns to "STAND-BY") shortly after the plate has left the dryer section.

The "REWASH" lamp (7) and the "WAIT" indicator (16) turn off.

NOTE! The "REWASH" procedure must be executed as described above for each plate that is entered for rewashing and regumming. This is to reset the timer function.

- To exit the "REWASH" program manually push the "REWASH" button (7) for 2 secs. until the built-in lamp and the "WAIT" indicator (16) turn off.

The processor stops and returns to "STAND-BY" mode.

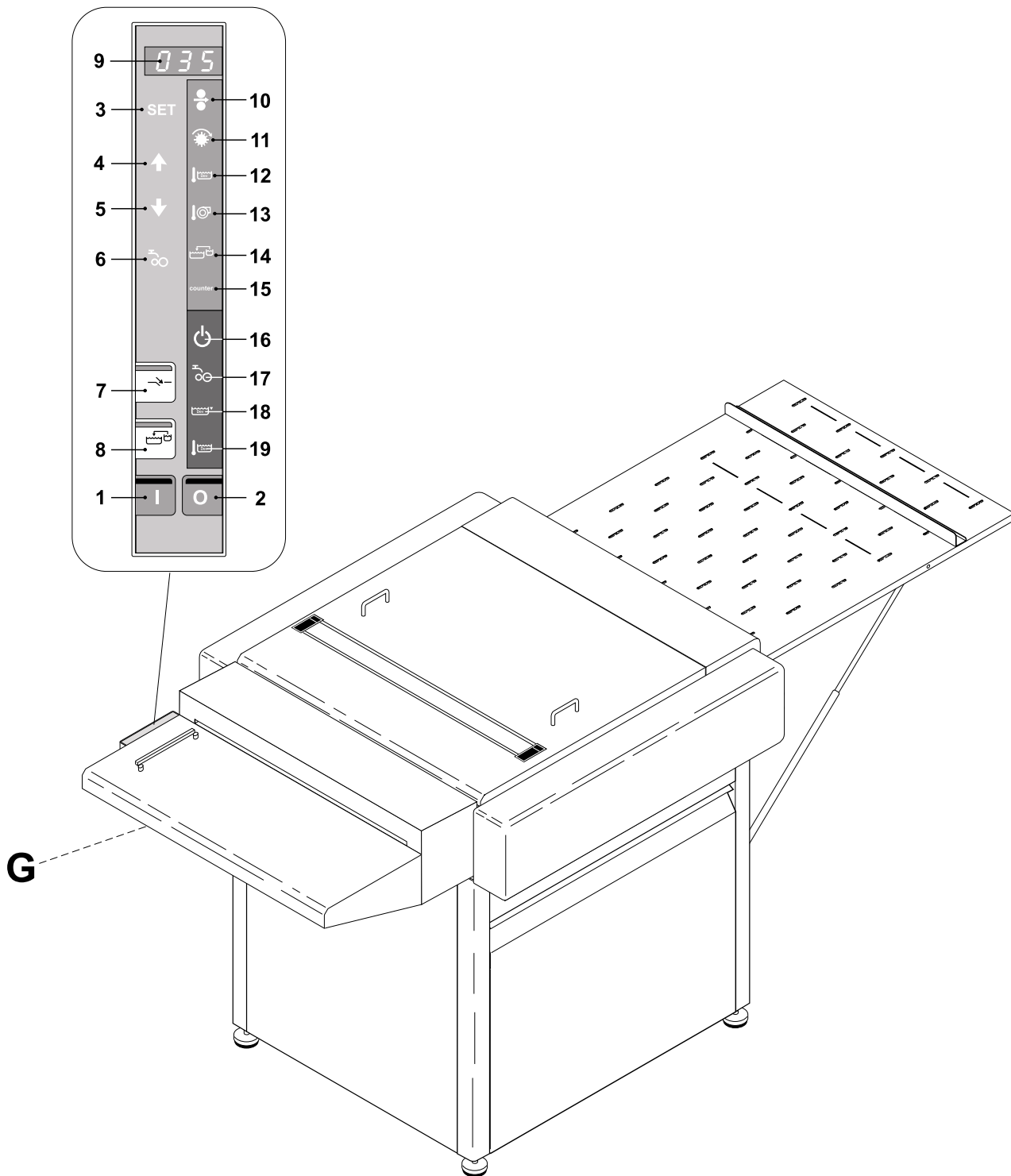

5. CLEANING AND MAINTENANCE

5-1. GENERAL

Performing cleaning and maintenance regularly reduces the chances of equipment failure and the loss of processing quality.

Only one person should be responsible for performing the preventive maintenance program. That person should be familiar with the equipment as well as its operational characteristics and maintenance requirements.

The major clean-up procedure can be performed in two to four hours depending on the condition of the machine and on the proficiency of the person cleaning it.

NOTE! Personnel performing any maintenance, cleaning or servicing must familiarize themselves with the safety instructions and environmental protection described in chapter 0 before attempting any of these procedures.

CAUTION! Do not cover the machine with a cloth or piece of plastic to protect it from dust, as this prevents free circulation around the machine and can lead to condensation and overheating.

CLEANING ACCESSORIES

CAUTION! Never use hard tools or abrasive materials when cleaning any part of the processor.

Apron, rubber gloves and eye goggles.

For personal protection.

Lint-free cloth, sponge and soft brush.

For cleaning of rollers, guides and tank walls.

Longhandled bottle brush and thin wire (ex. paper clip).

For cleaning the inside and the holes of the spray tubes.

CLEANING AGENTS

WARNING! Never use cleaning agents containing chlorinated solvents or acetic or phosphoric acid. These constitute a health hazard and could damage the processor.

Warm water 35-40°C (95-104°F).

For normal cleaning purposes and to rinse after using other cleaning agents.

Citric acid 10%/Nitric acid 5%

For major cleaning purposes.

Commercially available biocide/strong alkalic liquid

For cleaning off heavy algae-, fungal- or bacterial growth in the wash section.

BEARING BLOCKS

Most of the bearing blocks are fabricated with coarse chamfers in one end (see illustration). When a bearing has been removed from the processor for cleaning etc. it is very important for the correct function of the machine that this end is mounted downwards in the tank.

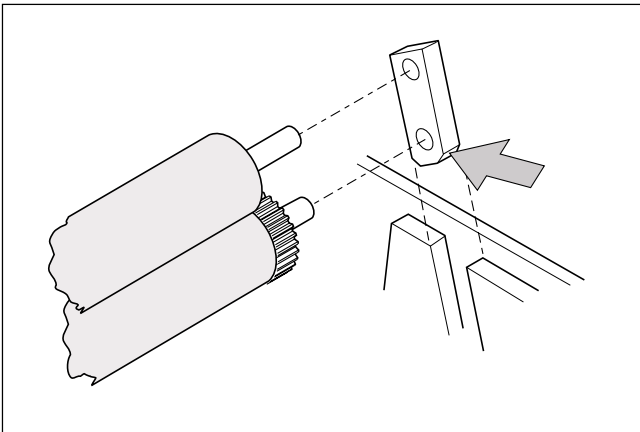

SPRAY TUBES

When a spray tube has been removed from the processor for cleaning or servicing purposes make sure to reinstall it properly:

(See illustration below)

- Insert the tube into the hole in the right tank side.
- Lower the spray tube into the groove in the left tank side pushing it all the way to the bottom of the groove making sure that the groove **(1)** in the spray tube fits onto the notch **(2)** in the bottom of the groove.

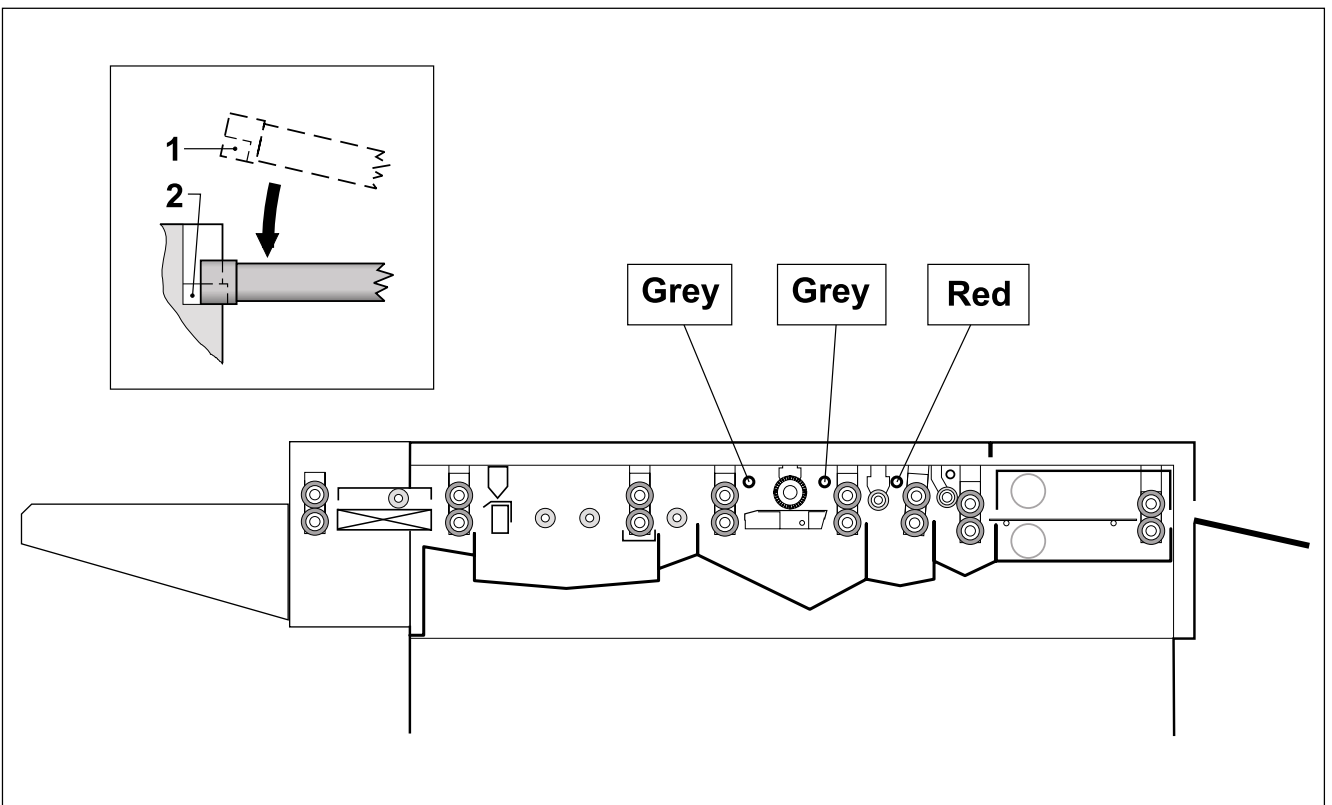

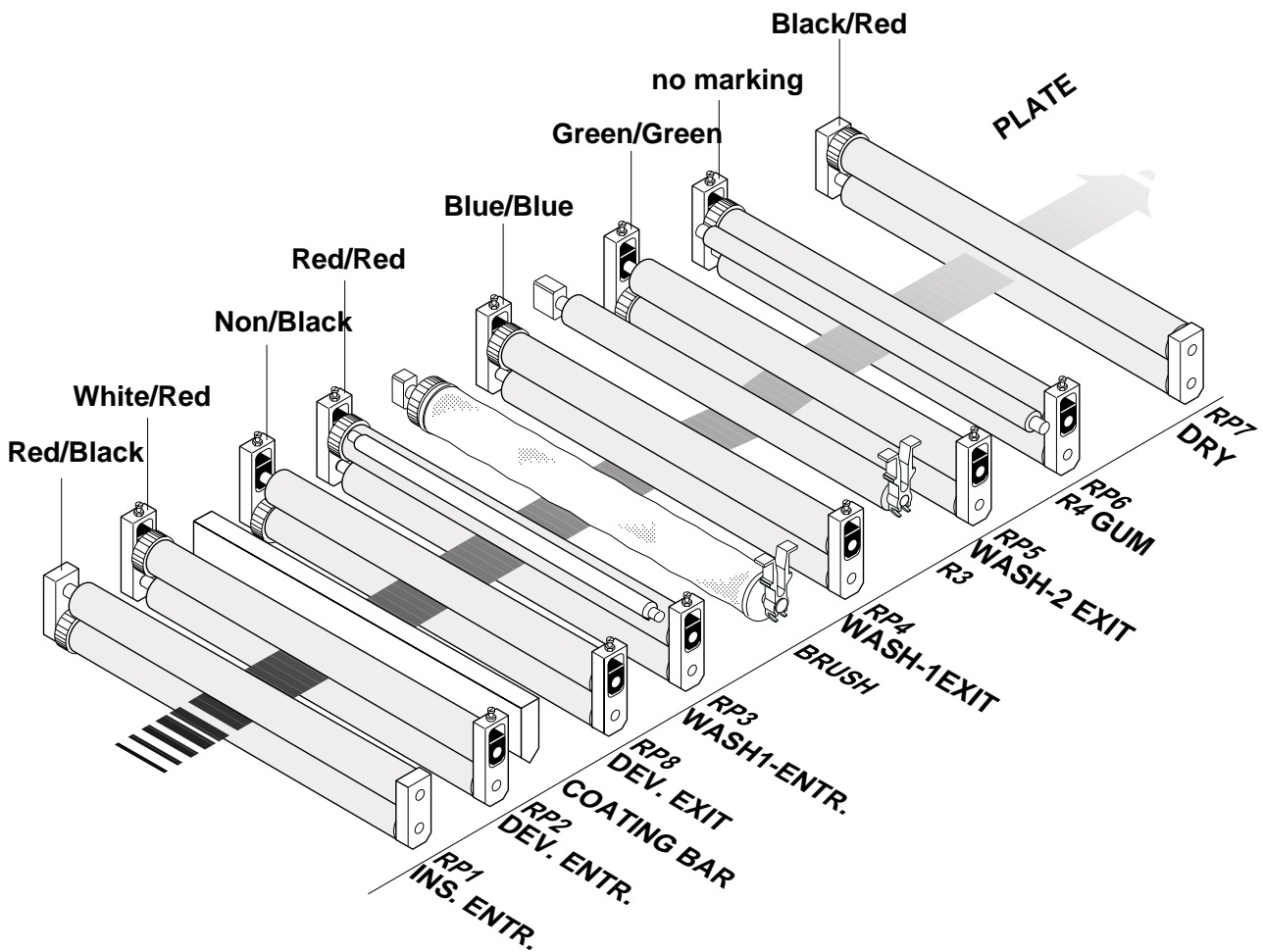
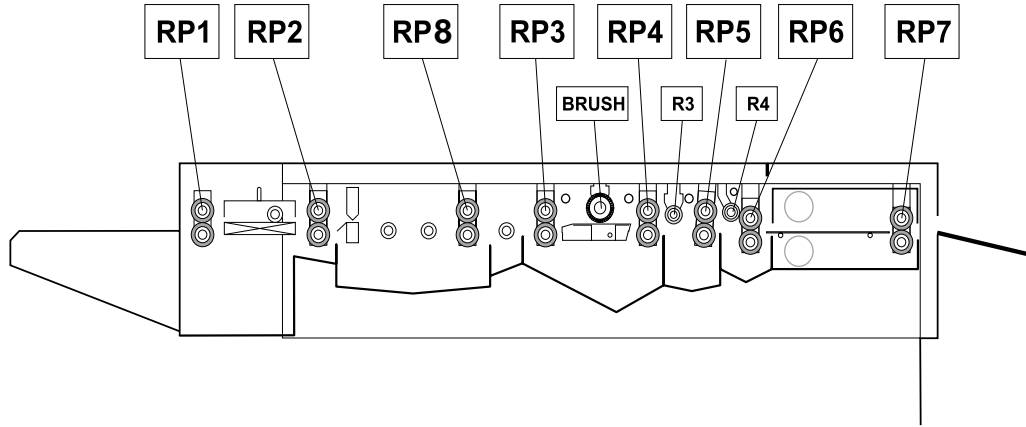

IDENTIFICATION OF ROLLERS

(See the illustration on the previous page.)

This processor is equipped with eight pairs of rollers (RP1 to RP8). These rollers are not all alike in the way they are positioned and the location of their drive gears.

When the rollers and bearings are removed for purposes such as cleaning, it is very important for the correct function of the machine that all parts are reattached in their proper positions. For this purpose every pair of rollers, except RP6, is marked with a combination of color-coded O-rings.

The correct configuration and locations of the roller pairs are as described below and as shown in the illustration on the previous page.

RP1 (Ins. entrance): (Red/Black)
 Upper roller Rubber, beige (EPDM)
 Lower roller Rubber, beige (EPDM)
 Bearing Ordinary
 Gear On lower roller

RP2 (Dev. entrance): (White/Red)
 Upper roller Rubber, black (EPDM)
 Lower roller Rubber, black (EPDM)
 Bearing Adjustable
 Gear On upper roller

RP3 (Wash 1 entrance): (Red/Red)
 Upper roller Rubber, beige (EPDM)
 Lower roller Rubber, beige, bulged (EPDM)
 Bearing Adjustable
 Gear On upper roller

Brush:
 D50 (Complete)
 Bearing, left
 Bearing, right

RP4 (Wash 1 exit): (Blue/Blue)
 Upper roller Rubber, beige (EPDM)
 Lower roller Rubber, beige, bulged (EPDM)
 Bearing Adjustable

RP5 (Wash 2 exit): (Green/Green)
 Upper roller Rubber, beige (EPDM)
 Lower roller Rubber, beige, bulged (EPDM)
 Bearing Adjustable
 Gear On lower roller

R4:
 PUR, D30

RP6 (Gum): (No marks)
 Upper roller Rubber, beige (NITRIL)
 Lower roller Rubber, beige, bulged (NITRIL)
 Bearing Adjustable
 Gear On upper roller

RP7 (Dry): (Black/Red)
 Upper roller Rubber, beige (EPDM)
 Lower roller Rubber, beige (EPDM)
 Bearing Ordinary
 Gear On upper roller

RP8 (Dev. exit): (None/Black)
 Upper roller Rubber, black (EPDM)
 Lower roller Rubber, black, bulged (EPDM)
 Bearing Adjustable
 Gear On lower roller

5-2. CLEANING/MAINTENANCE INTERVALS

Refer to the table below for information about when and what to clean.

The cleaning and maintenance procedures are described on the following pages.

NOTE! Use table below as a guide. The cleaning intervals must always correspond to the duty level of the processor.

| OPERATION | Dayly | Weekly | 2 weeks | Monthly | 1/4 yearly |
|---|-------|--------|---------|---------|------------|
| GENERAL | | | | | |
| SAFETY CHECK, MECHANICAL | X | | | | |
| CHECK CONTAINER CONTENTS | | X | | | |
| CLEANING, PROCESSOR EXTERIOR | | | | | X |
| LUBRICATION, GEARS | | | | | X |
| CHANGING FILTERS (see 1)) | | | | | |
| DEVELOPER SECTION | | | | | |
| NORMAL CLEANING | | X | | | |
| CHANGE DEVELOPER | | | | | |
| WASH-OFF SECTION | | | | | |
| MAJAR CLEANING | | | | X | |
| CHANGE STABILIZER (or every 250m ²) | | | X | | |
| GUM SECTION | | | | | |
| NORMAL CLEANING | X | | | | |
| MAJAR CLEANING | | X | | | |
| DRYER SECTION | | | | | |
| NORMAL CLEANING | X | | | | |

1) Filter Change intervals :

Wash-off filters : After every 150m² plates proceed.

2) Gum solution Change intervals :

5 litres / week or After every 250m² plates proceed. (Using gum-linse function)

| |
|--------------------------|
| 5-3. SAFETY CHECK |
|--------------------------|

MECHANICAL

Check proper function/location of:

- Left/right fenders
- Top cover.
- Dryer covers.
- Cover, electronics drawer.

5-4. CHECK OF CONTAINER CONTENTS

Developer replenishment

Check that the container is sufficiently filled.
 Refill or replace if necessary.

Wash-off replenishment

Check that the container is sufficiently filled.
 Refill or replace if necessary.

NOTE! After changing a container the container level function must be reset.

Gum

Check that the container is sufficiently filled.
 Refill or replace if necessary.
 Replace gum if it is dirty, to thin or to thick.

Waste containers

Check that the waste containers are not almost full.
 Empty or replace if necessary.
 When one or more replenishment containers have been exchanged it is very important that the correct hoses are connected to them:

Developer replenishment: Clear hose

Wash-off replenishment: Blue hose

Gum: Clear hose

**RESETTING OF THE
 CONTAINER LEVEL FUNCTION**

When one or both of the developer or wash-off replenishment containers have been replaced with full containers the electronics has to be reset as described below:

- Push the “REPLENISHMENT” button **(8)** on the control panel and hold it for 3 secs.
- The display will change to show either “1 __” or “1 - ” indicating the status (empty/not empty) of the developer replenishment container.
- Reset the container status to “1 - ” (full) by pushing “SET” button **(3)** once.
 If status is “1 - ” before resetting, the display will change to “1 __” and then to “1 - ” again to confirm resetting.
- Push “REPLENISHMENT” button again and the display will change to show either “2 __” or “2 - ” indicating the status (empty/not empty) of the wash-off replenishment container.
- Reset the container status to “2 - ” (full) by pushing “SET” button **(3)** once.
- Push the “REPLENISHMENT” button **(8)** to exit the function.

5-5. CLEANING, PROCESSOR EXTERIOR

Accessories:

- Lint free cloth

Cleaning agents:

- Warm water.

- Wipe clean all surfaces (especially the feed table and the exit table).

NOTE! Do not use any abrasive materials when cleaning the processor panels.

5-6. LUBRICATION, GEARS

- Lubricate all gears using Alu-grease.
(Type PAL TP 1054 or equivalent).

5-7. CHANGING OF FILTERS

Clean the filters regularly as described below:

(See illustration)

- Place the drip tray (1) underneath the filter.
- Close the two valves (2), one on each side of the filter housing.
- Open the drain valve (3) to empty the filter vessel.
- Unscrew the filter vessel (4) carefully.
- Take the filter element (5) out and change it whatever is necessary.
- Install the filter element again, and mount the filter vessel (4) observing that the O-ring (6) is properly fitted in the groove of the filter vessel.
- Close the valve (3) and open the valves (2) again.
- Before starting the processor open valve (3) and drain out app. 100 ml.
(The drained out solution should be poured back into the respective section).

Stabilizer flow :

Wash-off 1 > Pump > Filter 1 > Filter 2 > Spray

Filter 1 should be 25micron

Filter 2 should be 3micron

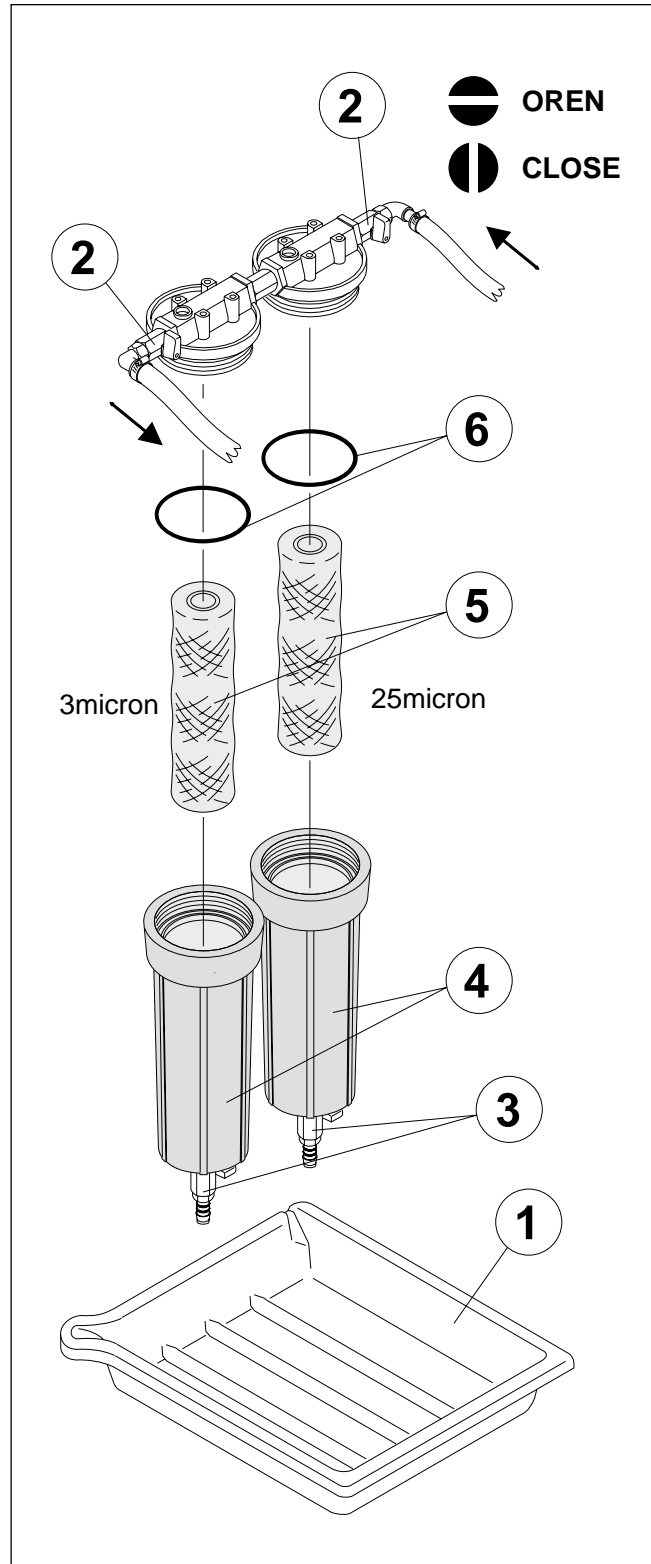

5-8. CLEANING, DEVELOPER SECTION

NORMAL CLEANING



WARNING

Wear appropriate protective gear, such as glasses, rubber gloves, mask, and apron.

6)After the inside of the developing tank has been cleaned, restore the rollers and guides into respective positions.

Accessories: Waste cloth, sponge

Cleaning agents: Neutral detergent, Warm water

1)Remove all rollers and guides from the developer section and bring them to the wash place.

Note! Never remove the support. If the gap between the support and the coating bar goes out of adjustment, it will cause uneven developing.

2)Moisten the sponge with neutral detergent and thoroughly clean dirt off all the rollers and guides.

3)Sufficiently rinse neutral detergent off all the rollers and guides with hot or tap water.

4)Thoroughly wipe water off all the rollers and guides with dry waste cloths.

5)Wash the inside of the developing tank with a waste cloth or sponge while trickling tap water into the tank. If there is heavy buildup of dirt, use hot water to enhance cleaning.



WARNING

Although the coating section can be easily cleaned by turning the coating bar, be sure to securely hold the coating bar by hand during cleaning.

5-9. CHANGING THE DEVELOPER(cubitainer)



WARNING Wear appropriate protective gear, such as glasses, rubber gloves, mask, and apron.

It is unnecessary to replace developer under standard usage conditions.

If one of the conditions below is met, replace the cubitainer containing developer to ensure proper development. (Refer to “ Developer (cubitainer) replacement procedure”.)

- 1)The remaining quantity of developer in the cubitainer is less than 1 liter.
(The remaining cubitainer, if it is normal, can be used after it is re-contained into another cubitainer.)
- 2)The remaining developer gets discolored.
- 3)Foreign substances, such as precipitate and/or suspended solids, exist in developer.
- 4)Another obvious abnormality exists.

Note! Be careful not to let any foreign substances get into developer.

DEVELOPER (cubitainer) REPLACEMENT PROCEDURE

- 1)Remove the suction pipe from the cubitainer.
- 2)Uncap the new cubitainer and attach the suction pipe to the cubitainer.
At this time, ensure that as little air as possible is in the cubitainer.
- 3)Open the air vent valve of the developer pump by turning its knob 1.5 to 2 turns.

Note! Never turn the knob more than 2.5 turns to prevent a leak of developer.

- 4)Press the developer supply pump button.
- 5)After the pump stops three minutes later, close the air vent valve of the pump by turning its knob.
- 6)Confirm that no air remains in the hose and the pump. Then the cubitainer replacement work is completed.

If air remains in the hose or the pump, it may cause developer error. If it remains, bleed them following the procedure in “Bleeding procedure”.

CLEANING THE DEVELOPER SECTION

| | |
|---|--|
|  WARNING | Wear appropriate protective gear, such as glasses, rubber gloves, mask, and apron. |
|---|--|

Accessories: Waste cloth, sponge

Cleaning agents: Neutral detergent

- 1) Remove all rollers and guides from the developer section and bring them to the wash place.

Note! Never remove the support. If the gap between the support and the coating bar goes out of adjustment, it will cause uneven developing.

- 2) Moisten the sponge with neutral detergent and thoroughly clean dirt off all the rollers and guides.
- 3) Sufficiently rinse neutral detergent off all the rollers and guides with hot or tap water.
- 4) Thoroughly wipe water off all the rollers and guides with dry waste cloths.
- 5) Wash the inside of the developing tank with a waste cloth or sponge while trickling tap water into the tank. If there is heavy buildup of dirt, use hot water to enhance cleaning.

REPLACING DEVELOPER (cubitainer)

| | |
|---|--|
|  WARNING | Wear appropriate protective gear, such as glasses, rubber gloves, mask, and apron. |
|---|--|

It is unnecessary to replace developer under standard usage conditions.

If one of the conditions below is met, replace the cubitainer containing developer to ensure proper development. (Refer to “ Developer (cubitainer) replacement procedure”.)

- 1) The remaining quantity of developer in the cubitainer is less than 1 liter.
(The remaining cubitainer, if it is normal, can be used after it is re-contained into another cubitainer.)
- 2) The remaining developer gets discolored.
- 3) Foreign substances, such as precipitate and/or suspended solids, exist in developer.
- 4) Another obvious abnormality exists.

Note! Be careful not to let any foreign substances get into developer.

BLEEDING PROCEDURE

This section describes the procedure for bleeding the developer pump and the hose if air remains inside them.

- 1) Check that there is sufficient developer in the cubitainer.
- 2) Check that the developer suction pipe is securely and hermetically fit to the cubitainer.
- 3) Turn the knob of the air vent valve, which is located on the dispense side of the developer pump, 1.5 to 2 turns. Then, developer running out of the pump flows directly into the waste liquid tank.

Note! Never turn the knob more than 2.5 turns to prevent a leak of developer.

- 4) To activate the pump, press the developer pump manual operation button (red button on the left side) on the control panel once.
When the developer pump manual operation button is pressed once, the pump operates for 3 minutes. Pressing the button again while the pump is operating stops the pump.
- 5) Move the hose up and down to encourage air-flow into the developer pump for removal.
- 6) After air is completely removed from inside of the hose and the developer pump, press the developer pump manual operation button again to stop the pump.
- 7) Completely close the air vent valve by turning its knob, to change the direction of the developer flow to the coating head.
- 8) To remove air between the developer pump and the coating head, activate the developer pump by pressing the developer pump manual operation button on the control panel once again.

- 9) To remove air trapped in the coating head, turn the coating head upward slightly from the horizontal position.

If there is air in the coating head, bubbles form at both ends of the slit.

Be sure to hold the coating head securely while bleeding it.

- 10) Check that air is completely removed and the developer dispense is stable, return the coating head to the previous status.
- 11) Finally, press the developer pump manual operation button to stop the pump.

Note! If air remains in the hose, pump, and/or coating head, it may cause developer error. Therefore, make sure that these parts are completely bled.

DEVELOPER SECTION MANAGEMENT in cases when the machine is left off

This section describes the procedure that should be performed if the processor will not be used for an extended period of time.

- 1) Prepare a container of 5 to 10 liters capacity and fill it with water.
- 2) Remove the developer suction pipe from the cubitainer, and remove air from the cubitainer and then cap it.
- 3) Insert the developer suction pipe into the container filled with water.
- 4) Press the developer pump manual operation button and keep the developer pump in operation for 4 to 5 minutes.
- 5) Confirm that the hose is filled with water in place of developer, and then stop the developer pump.
- 6) After the pump is stopped, remove the top of the processor and remove dirt off the developer head and the support.

Note! The coating head is able to rotate more than 180 degrees. Hold it securely by hand during the work.

- 7) Remove the pair of the developer squeeze rollers and drain liquid from the vat under the squeeze rollers.
(The vat can be removed.)
- 8) After cleaning the pair of the developer squeeze rollers and the under vat, restore them in position.
- 9) Keep the developer suction pipe in the container filled with water until use of the processor is resumed again.
- 10) When resuming use of the processor, thoroughly replace the water with developer,

contrary to the procedure above. At this time, be sure to perform bleeding procedure properly. (Refer to "Bleeding procedure".)

Note! If developer is left in the hose, the pump, or the coating head for a long time, the developer may get discolored and/or crystallized, thereby could cause a jam or other troubles.

5-10. REMOVING THE BRUSH/STOP ROLLER

When performing any cleaning or servicing in the wash-off section it will be necessary to remove the brush (or stop roller).

The procedure is as follows:
(See illustration opposite)

STEP 1:

Push together the clamps of the special bearing in the right side.

STEP 2:

Lift out the brush/roller in the right side.

STEP 3:

Pull out the brush/roller and the small bearing from the left tank side.

Reinstall the brush/roller in reverse order making sure that

- the small bearing in the left side is fitted properly in the respective hole.
- both of the clamps of the special bearing locks properly in the tank wall.

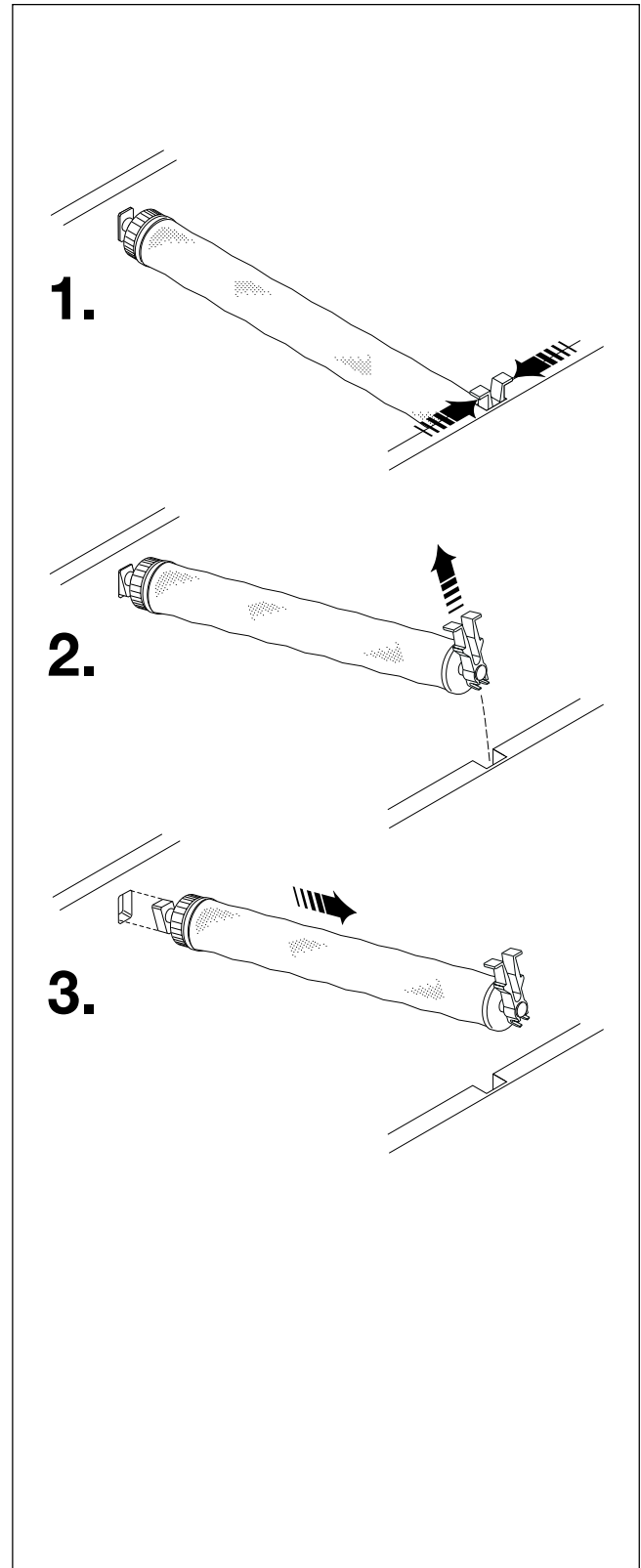

5-11. REPLACING THE BRUSH ROLLER CLOTH

The brush roller cloth can be replaced in case of heavy fouling or wear.

(See illustration below).

- Take out the brush roller as described in “REMOVING THE BRUSH/STOP ROLLER”.
- Dismount the special bearing (1) by pulling it upwards.
- Unscrew the disc (2) and loosen the disc (3).
- Pull off the cloth (4).
- Apply the new cloth (use talcum), wrap it round the roller edge in the gear wheel end and tighten the disc (3).
- Stretch the cloth to obtain a smooth fit along the roller, wrap it round the roller edge and hold it while tightening the disc (2).
- Fit the special bearing to the roller making sure of correct orientation of the spring clamp.
- Reinstall the brush roller.

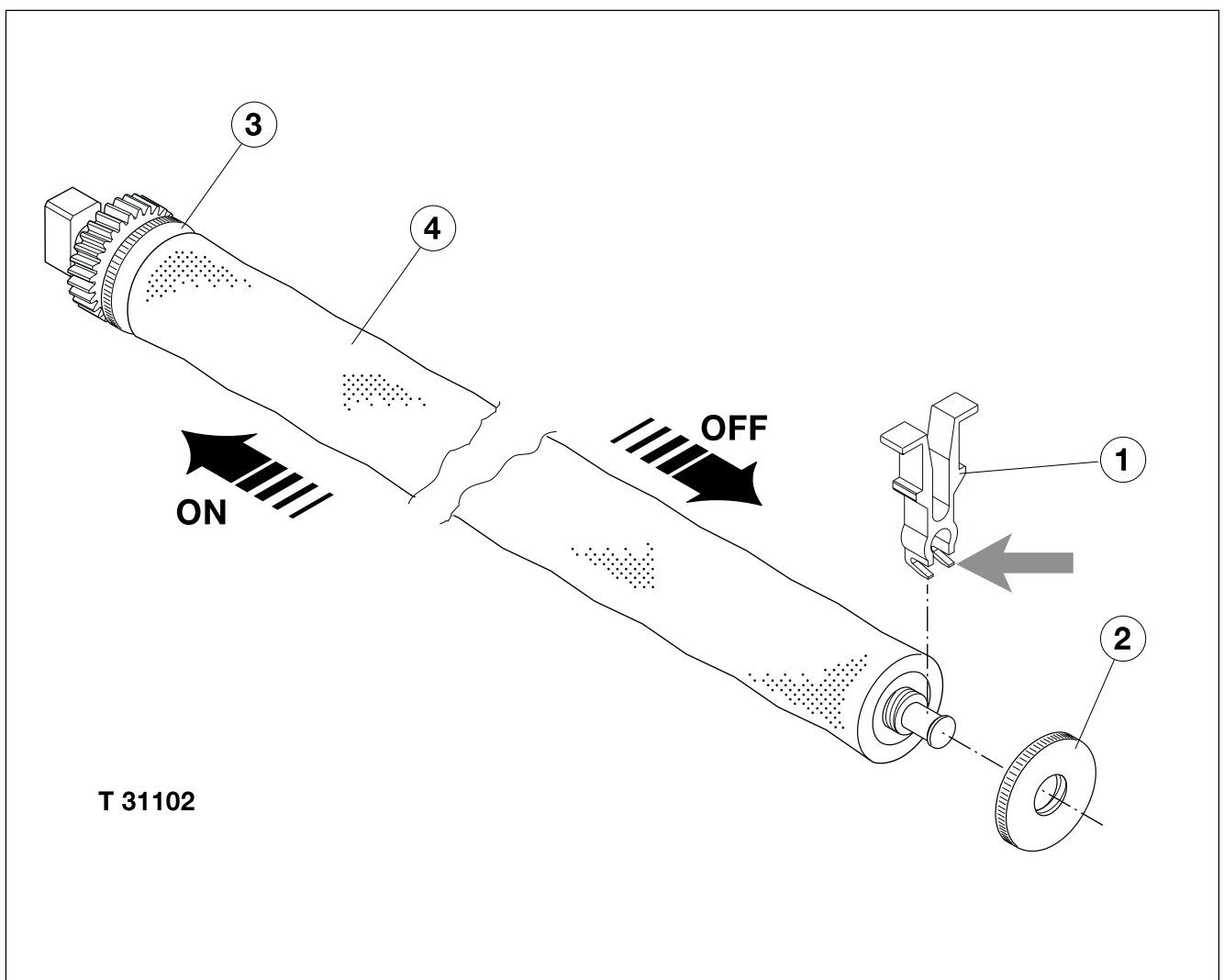

5-12. CLEANING, WASH-OFF SECTION

Accessories:

- Lint free cloth
- Brush
- Long handled bottle brush

Cleaning agents:

- Warm water.

- Drain both of the wash-off sections down to a level of app. 3 cm. The solution should be drained into a waste container.
- Remove spray tubes, rollers and guides from the sections and clean them separately:
 - Clean rollers and guides with warm water and dry them.
Use the bottle brush to clean the inside of the spray tubes.
Clean the holes in the spray tube using the paper clip.
 - Clean the wash-off filters with water.
(See “CHANGING OF FILTERS” earlier in this chapter).
- Remove any deposits from the tank walls and bottom using the brush.
- Drain the remaining solution.
- Rinse the tank with warm water and drain it.
- Fill the sections with fresh solution until it starts to overflow.
- Reinstall all parts in their proper positions.

5-13. CHANGING THE WASH-OFF SOLUTION

The wash-off solution should be changed regularly to maintain the processing quality of the processor. Show the "Technical Guide for plate" for intervals.

(See illustration below).

- Shut down the processor completely.
(See "SHUTDOWN PROCEDURE" in chapter 4 earlier in this manual).
- Lead the wash-off drain hose (1) into an empty waste container of min. 20 liters.
- Open the drain valves (2) and (3).
- When tank is empty clean it if necessary (see description earlier in this chapter).

- Drain wash-off filters and exchange or clean the filter elements as described in "CHANGING OF FILTERS" earlier in this chapter).
- Close the valve (2) and (3).
- Fill the sections with fresh solution until it starts to overflow.

NOTE! It will be necessary to top up the level in the wash-off sections shortly after start-up as the filter vessels now will be filled with wash-off solution.

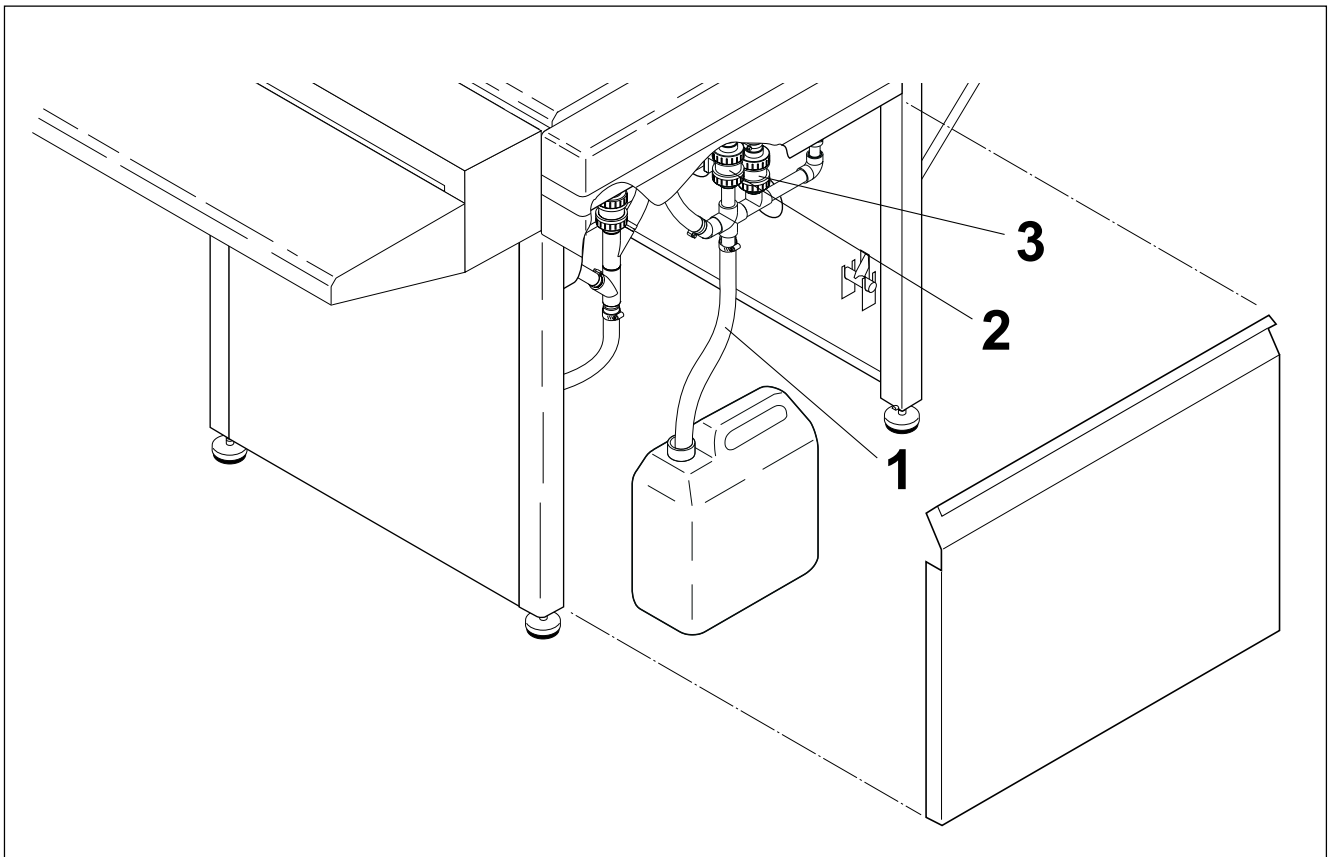

5-14. CLEANING, GUM SECTION

NORMAL CLEANING

When the processor is in "STAND-BY" the gumming function runs at intervals to prevent sticking of the gum rollers.

Additionally it is recommended to run the automatic "GUM-RINSE" program every day when shutting the processor down.

RUNNING THE GUM-RINSE PROGRAM

NOTE! The "GUM-RINSE" program should be performed at least once a day.

- The processor must be in "STAND-BY" mode.
- Press the "GUM-RINSE" button (6) and hold it for 3 secs.
- The "GUM-RINSE" program starts, the "GUM-RINSE" lamp (17) and the "WAIT" lamp (16) will start to flash asynchronously ("WAIT" lamp is on when the "GUM-RINSE" lamp is off and opposite).
- The display will show the current code for the AUTO-start function for 10 secs.:
 - A - AUTO-start switched on
 - O - AUTO-start switched off.
 Within the 10 secs. you can change the current code by pushing the "SET" button (3) and change the code by means of the selection buttons (4) or (5). Push "SET" (3) again to confirm new setting. The display will turn off after app. 10 secs.
- To skip the rinse programs before time-out push the "OFF" button (2).

NOTE! If rinse program is skipped before time-out, wait for app. 1 min. before switching off the processor.

- When the rinsing part of the program is finished the "ON" lamp (1) turns off and the "OFF" lamp (2) starts to flash indicating that the gum section is being emptied. After 1 min. the processor automatically switches to "OFF" mode.

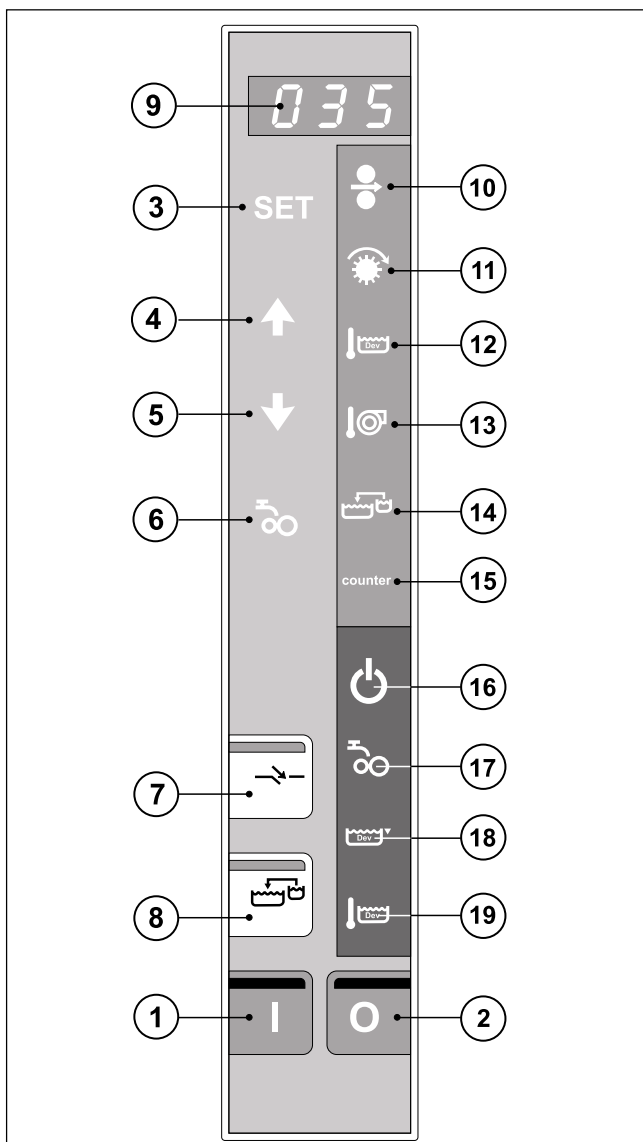

WEEKLY CLEANING

Accessories:

- Soft brush

Cleaning agents:

- Warm water
- Remove the rollers and the gum spray tube from the gum section and clean them in water.
- Wash the tank with warm water and a brush.
- Reinstall all parts again, observing that all parts are reinstalled in their proper place.

CLEANING OF THE GUM GRATE

(See illustration below).

The processor is equipped with a special grate in the drain opening of the gum section. The grate is designed to prevent the gum solenoid valve from being blocked if something mistakenly drops into the opening.

The grate should be taken out regularly and cleaned.

Remember to reinstall after cleaning.

