

P-α880

CTP-Processor

OPERATING INSTRUCTIONS	(GB)
BEDIENUNGSANWEISUNGEN	(D)
MODE D'EMPLOI	(F)
INSTRUCCIONES DE USO	(E)
ISTRUZIONI PER L'USO	(I)
ΟΔΗΓΙΕΣ ΛΕΙΤΟΥΡΓΙΑΣ	(GR)
BEDIENINGSHANDLEIDING	(NL)
KÄYTTÖOHJEET	(FIN)
INSTRUÇÕES PARA A OPERAÇÃO	(P)
BRUKSANVISNING	(S)
BETJENINGSVEJLEDNING	(DK)
DRIFTSINSTRUKSER	(N)
NOTKUNARLEIÐBEININGAR	(IS)



**MITSUBISHI
PAPER MILLS
LIMITED**

P- α 880

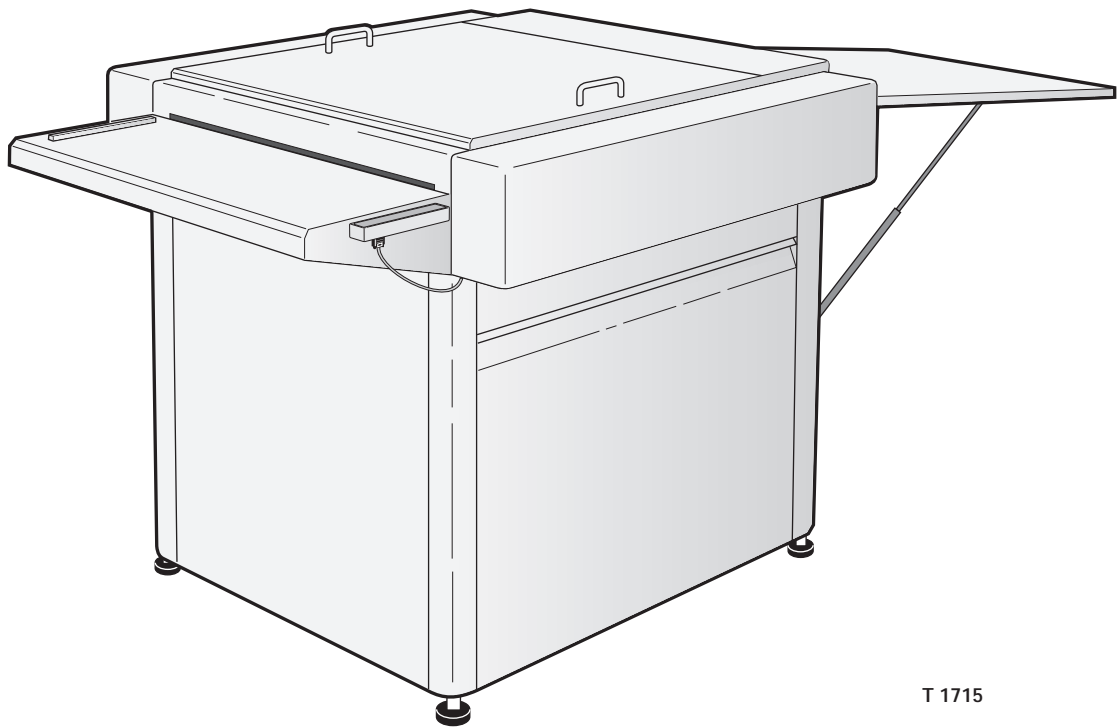

T 1715

**This manual is for the daily users of the equipment.
Always read the *Safety Instruction Manual part No 21741*
before starting up the equipment and keep it with the machine for
reference at all times.**

MPM SUPPORT OFFICES

MITSUBISHI PAPER MILLS, LTD.

Shin Nisseki Bldg., 4-2

Marunouchi 3-Chome

Chiyoda-Ku, Tokyo 100

JAPAN

Phone: +81 3-3123-3742

Fax: +81 3-3214-3976

MITSUBISHI IMAGING (MC), INC.

555 Theodore Fremd Avenue

Rye, N.Y. 10580

U.S.A.

Phone: +1 914-925-3202

Fax: +1 914-921-0995

MITSUBISHI PAPER GmbH

Wiesenstrasse 21

40549 Düsseldorf

GERMANY

Phone: +49 211-56849-0

Fax: +49 211-56849-22

0. INTRODUCTION

IMPORTANT!

- **Approvals:** The processor is manufactured according to legal demands. For compliance with the requirements the equipment is tested by Underwriters Laboratories or other accredited authority. Approvals will appear from the labels attached to the processor name plate or the frame part of the processor.
- **Intended use of the equipment:** Development of photographic materials as specified in “TECHNICAL SPECIFICATIONS” in chapter 1 in the service manual.
- **Installation:** It is the responsibility of the owner and operator/s of this processor, that the installation is made in accordance with local regulations, and by engineers authorized to carry out plumbing and electrical installations. Installation, service and repair must be performed only by service technicians who are trained in servicing the equipment. The installation procedure is described in “INSTALLATION” in chapter 2 in the service manual. The manufacturer cannot be held responsible for any damage caused by incorrect installation of this processor.
- **Technical data:** Observe technical data from the processor name plate located on the rear panel of the processor.
- **Chemicals:** This processor must only be used with chemicals provided by Mitsubishi Paper Mills. Always obey the product safety data sheets provided by the manufacturer.
- **Lithium Batteries:** Replace only with the same or equivalent type as recommended by the manufacturer. Dispose of used batteries according to the manufacturer’s instructions.

CAUTION! Make sure always to mount the battery with the positive (+) side upwards.

CAUTION! Danger of explosion if battery is incorrectly replaced.

THIS MANUAL

- **Intended use of this manual:** This manual is for the daily user of the equipment.
Always read the **Safety Instruction Manual part No 21741** before starting up the equipment and keep it with the machine for reference at all times.
- **Reservations:** This manual was written and illustrated using the best possible information available at the time of publication.
Any differences between this manual and the equipment reflect improvements introduced after the publication of the manual.
Changes, technical inaccuracies and typographic errors will be corrected in subsequent editions.
As a part of our policy of continuous improvement, we reserve the right to alter design and specifications without further notice.

WARNINGS, CAUTIONS AND NOTES!

Throughout the manual warnings, cautions, and notes are written in bold on a grey background like the example below:

CAUTION! Always replace a fuse with one of the same size and rating as the old one.

Explanation:

NOTE!

The operator should observe and/or act according to the information in order to obtain the best possible function of the equipment.

CAUTION!

The operator must observe and/or act according to the information in order to avoid any mechanical or electrical damage to the equipment.

WARNING!

The operator must observe and/or act according to the information in order to avoid any personnel injury.

TABLE OF CONTENTS

	PAGE
0. INTRODUCTION	3
IMPORTANT!	3
THIS MANUAL	4
WARNINGS, CAUTIONS AND NOTES!	4
1. FUNCTIONAL DESCRIPTION	7
GENERAL	7
MAIN COMPONENTS OVERVIEW	9
2. CONTROLS AND INDICATORS	13
THE CONTROL BOX	13
CONTROL PANEL LIGHT	14
FUNCTIONAL DESCRIPTION	14
ERROR/AUTO-START CODES	23
3. OPERATING PROCEDURES	25
OPERATING MODES	27
DAILY START-UP	31
SETTING THE PROCESSING PARAMETERS	31
PROCESSING FROM THE FEED TABLE	33
USING THE REWASH SLOT	35
SHUTDOWN PROCEDURE	37
NORMAL SHUT DOWN	37
COMPLETE SHUTDOWN	37

TABLE OF CONTENTS

.....	PAGE
4. CLEANING AND MAINTENANCE	39
GENERAL	39
CLEANING ACCESSORIES	40
CLEANING AGENTS	40
BEARING BLOCKS	41
SPRAY TUBES	41
IDENTIFICATION OF ROLLERS	43
CLEANING/MAINTENANCE INTERVALS	45
SAFETY CHECK	46
CHECK OF CONTAINER CONTENTS	47
RESETTING OF THE CONTAINER LEVEL FUNCTION	47
CLEANING, PROCESSOR EXTERIOR	48
LUBRICATION, GEARS	48
CHANGING.CLEANING OF FILTERS	49
CLEANING, DEVELOPER SECTION	50
NORMAL CLEANING	50
MAJOR CLEANING	50
CHANGING THE DEVELOPER	51
REMOVING THE BRUSH/STOP ROLLER	53
REPLACING THE BRUSH ROLLER CLOTH	54
CLEANING, WASH-OFF SECTION	55
CHANGING THE WASH-OFF SOLUTION	56
CLEANING, GUM SECTION	57
NORMAL CLEANING	57
RUNNING THE GUM-RINSE PROGRAM	57
WEEKLY CLEANING	58
CLEANING OF THE GUM GRATE	58

1. FUNCTIONAL DESCRIPTION

GENERAL

The processor contains 5 major sections (see illustration below): DEV **(A)**, WASH-OFF 1 **(B)**, WASH-OFF 2 **(C)**, GUM **(D)** and DRYER **(E)**. Each section performs a basic function to change the exposed plate into a fully developed and dry plate, ready for handling.

The plate material is fed into the machine from the feed-table **(F)** (Off-line) or from a plate setter (On-line).

At this stage the machine will normally be in STANDBY mode, but activating the input sensor(s) makes the machine start up in PROCESS mode (see description of the different operating modes later in this chapter).

When the plate is fed into the processor, the transport roller system takes over and leads it safely and smoothly through each of the five sections.

Shortly after the plate material exits, the machine returns to STANDBY mode.

The processor can be equipped with an exit table **(G)** (option).

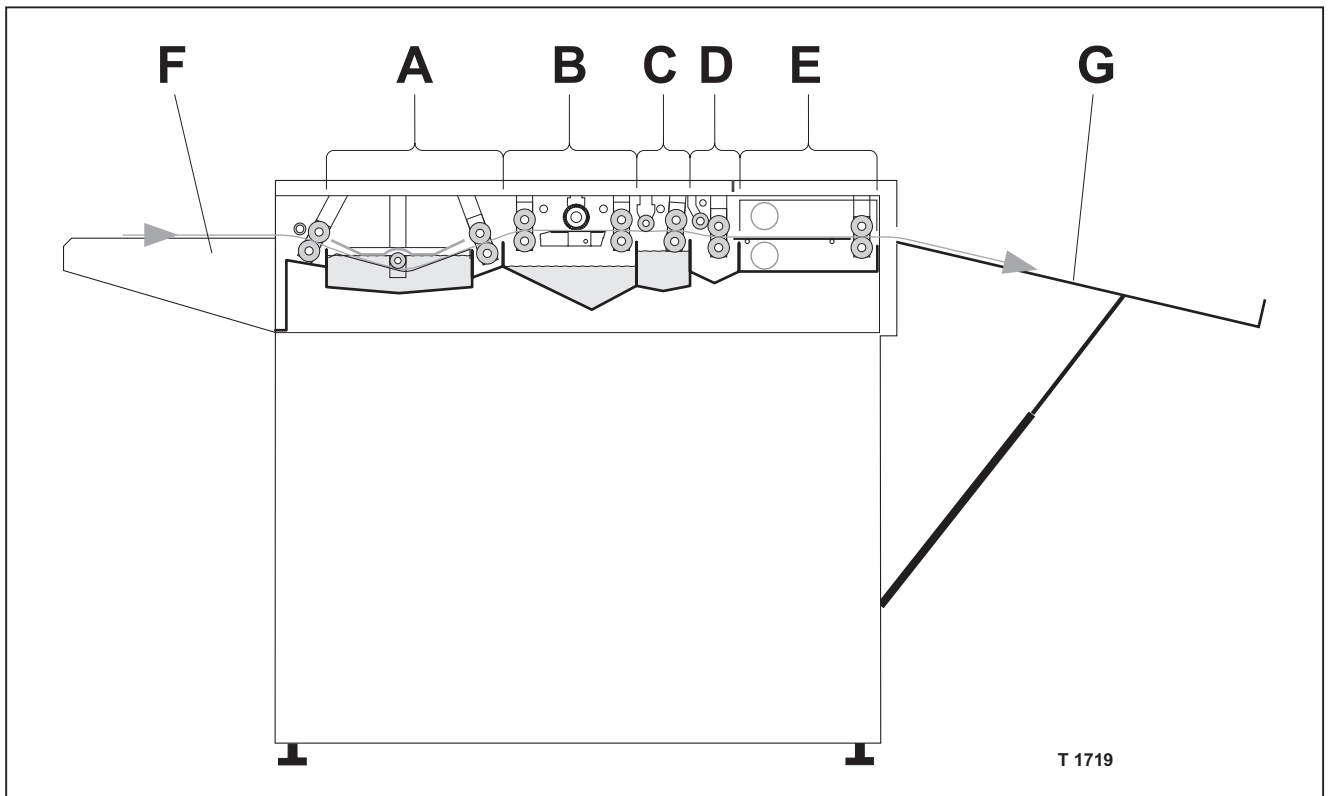

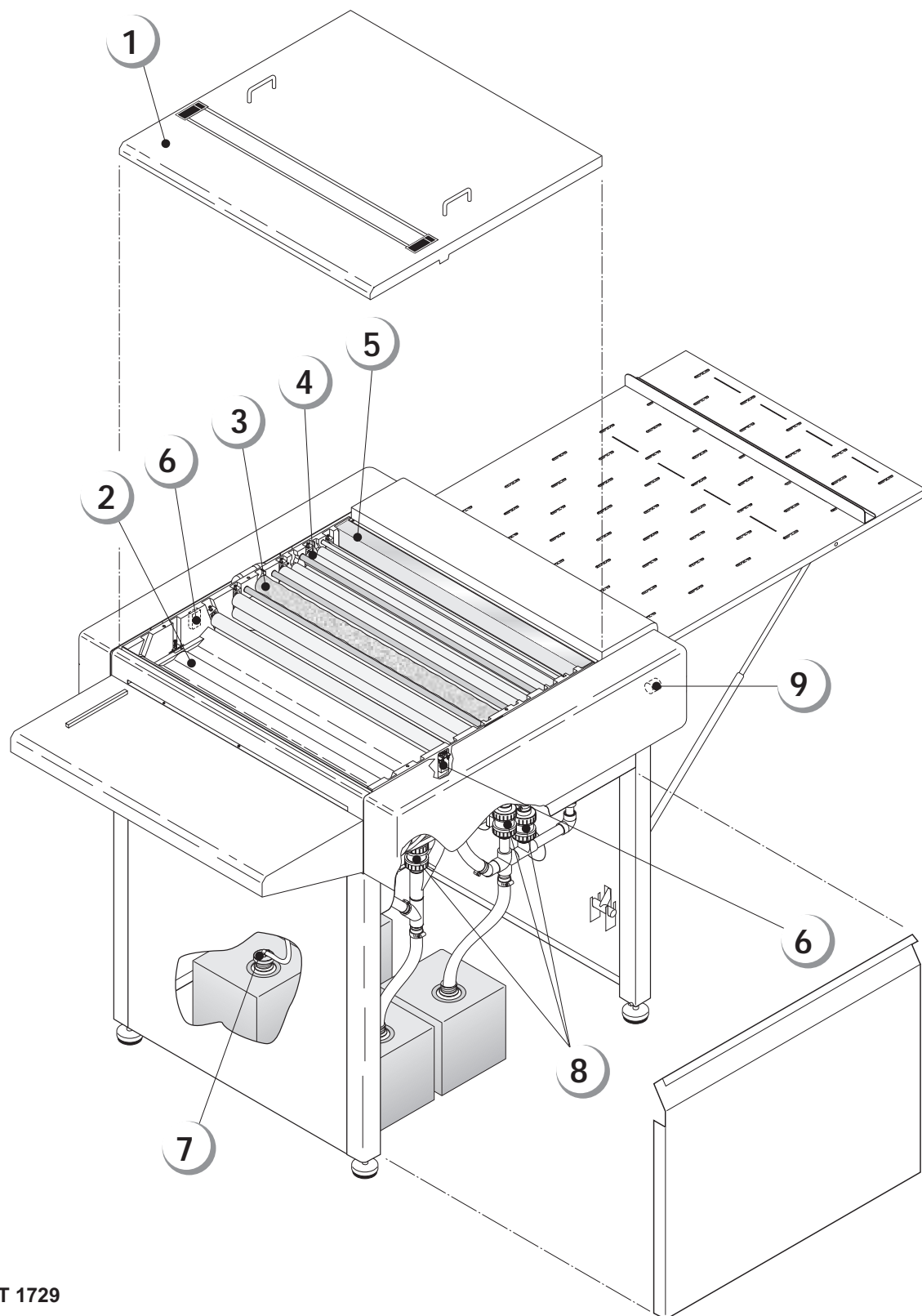

T 1729

MAIN COMPONENTS OVERVIEW

(See illustration opposite).

TOP COVER (1)

The top-cover can easily be removed when performing service and maintenance. When the top cover is lifted off, the interlock switches (6) turn off the power to all moving parts (rollers, pumps etc.) of the processor.

The top cover is equipped with a rewash-slot that makes it possible to enter a processed plate for washing-off, gumming and drying.

DEVELOPER SECTION (2)

See description in "DEVELOPER SECTION" later in this chapter.

WASH-OFF SECTION (3)

See description in "WASH-OFF SECTION" later in this chapter.

GUM SECTION (4)

See description in "GUM SECTION" later in this chapter.

DRYER SECTION (5)

See description in "DRYER SECTION" later in this chapter.

INTERLOCK SWITCHES (6)

The processor is equipped with 2 interlock switches, one on each side of the tank.

When the top cover is lifted off, the interlock switches turn off the power to all moving parts (rollers, pumps etc.) of the processor.

SUCTION TUBES (7)

Each replenishment hose is fitted with a special suction tube. When inserted into a replenishment container the suction tube ensures a tight fit preventing oxidation of the solution. Additionally the tubes are fitted with small filters to keep impurities out of the replenishment hoses.

DRAIN VALVES (8)

The developer- and wash-off sections are fitted with drain valves underneath the tank.

Use the drain valves to empty the sections when performing cleaning of the tanks or when exchanging the solution in the tanks.

COOLING UNIT PLUG (9)

If processor should be connected to a cooling unit, a plug for the electronic connection is located through the backside of the right fender.

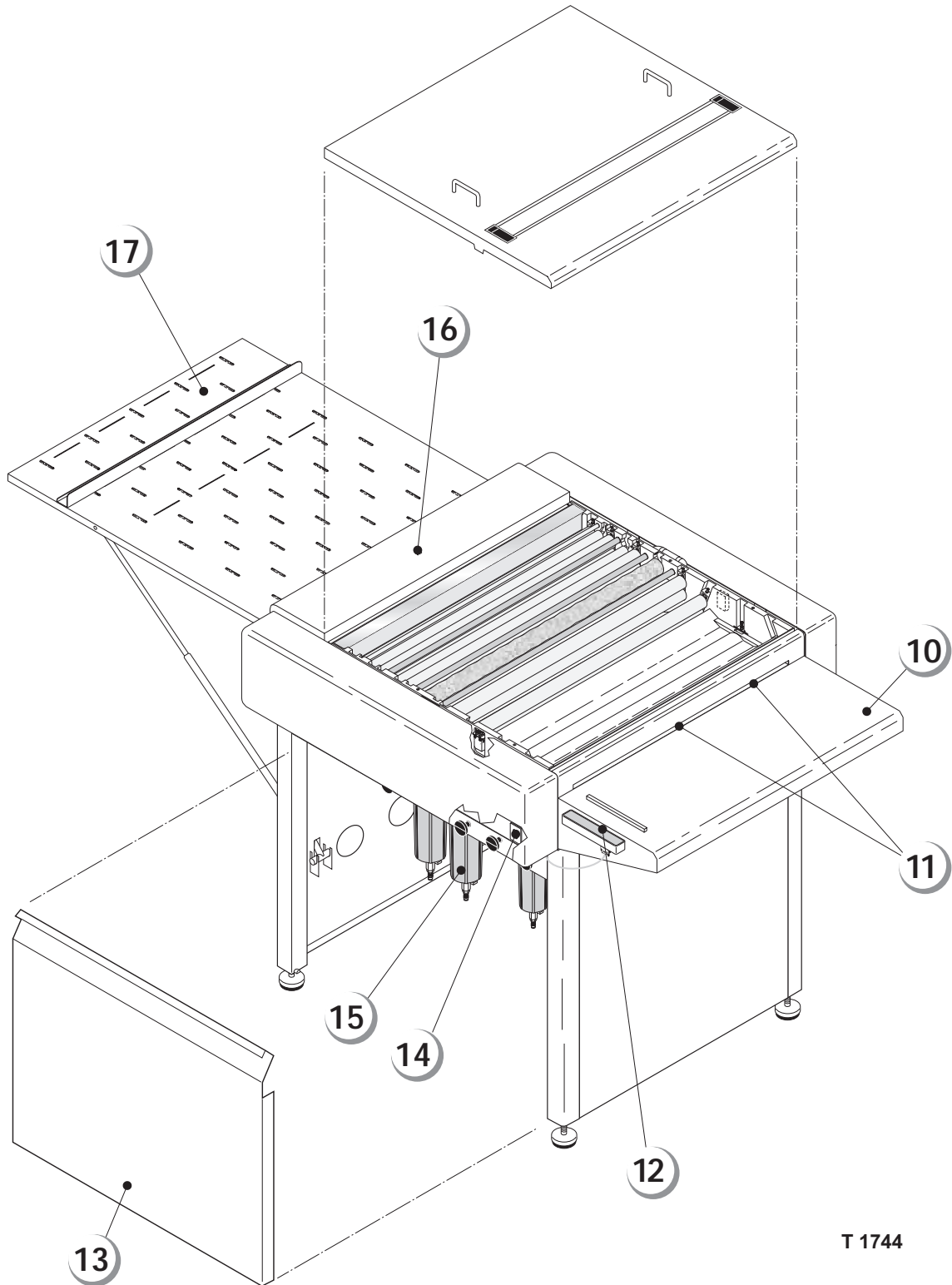

T 1744

FEED TABLE (10)

(Only off-line processors)

The plate is fed into the processor from the feed table. The feed table is equipped with a plate feed guide to ensure that the plate is fed straight into the processor.

INPUT SENSORS (11)

Activating the input sensors located in the plate feed entrance automatically starts the processor.

A counter function counts every activation of the input sensors and makes it possible to check the number of jobs processed in the machine.

The input sensor in the left side of the feed entrance is for off-line processors only.

CONTROL BOX (12)

The processor is operated from the Control Box. See detailed description of the various functions in chapter 4 later in this manual.

STAND PANELS (13)

The left and right panels of the stand can be removed to enable the operator to change containers, change filter elements and to drain the developer- and wash-off sections etc.

MAIN SWITCH (14)

The main switch is placed at the front of the electronics drawer located through the upper left side of the stand.

FILTERS (15)

The developer- and wash-off solutions are continuously circulated through filters located underneath the processor:

Developer filter: 25 micron

Wash-off filters: 75 micron + 1 micron

OUTPUT SENSOR (16)

(Only on-line processors)

The output sensor placed at the dryer section exit helps to detect plate jam. If the output sensor is not activated within a preset time from when the input sensor(s) (11) was activated a plate jam may have occurred.

EXIT TABLE (17)

(Option)

When processed the plate ends on the exit table. The telescopic supports underneath the table makes it possible to adjust the slope and the output bracket can be fitted in three (3) different positions to match the plate size.

- GB -

2. CONTROLS AND INDICATORS

THE CONTROL BOX

The operation of the processor is controlled from the Control Box (see illustration below).

The functions of the Control Box lamps and buttons are described on the next pages.

The Control Box holds buttons and indicator lamps for all the main processor functions, buttons for setting of the various speeds and temperatures of the system, and a display showing the set values.

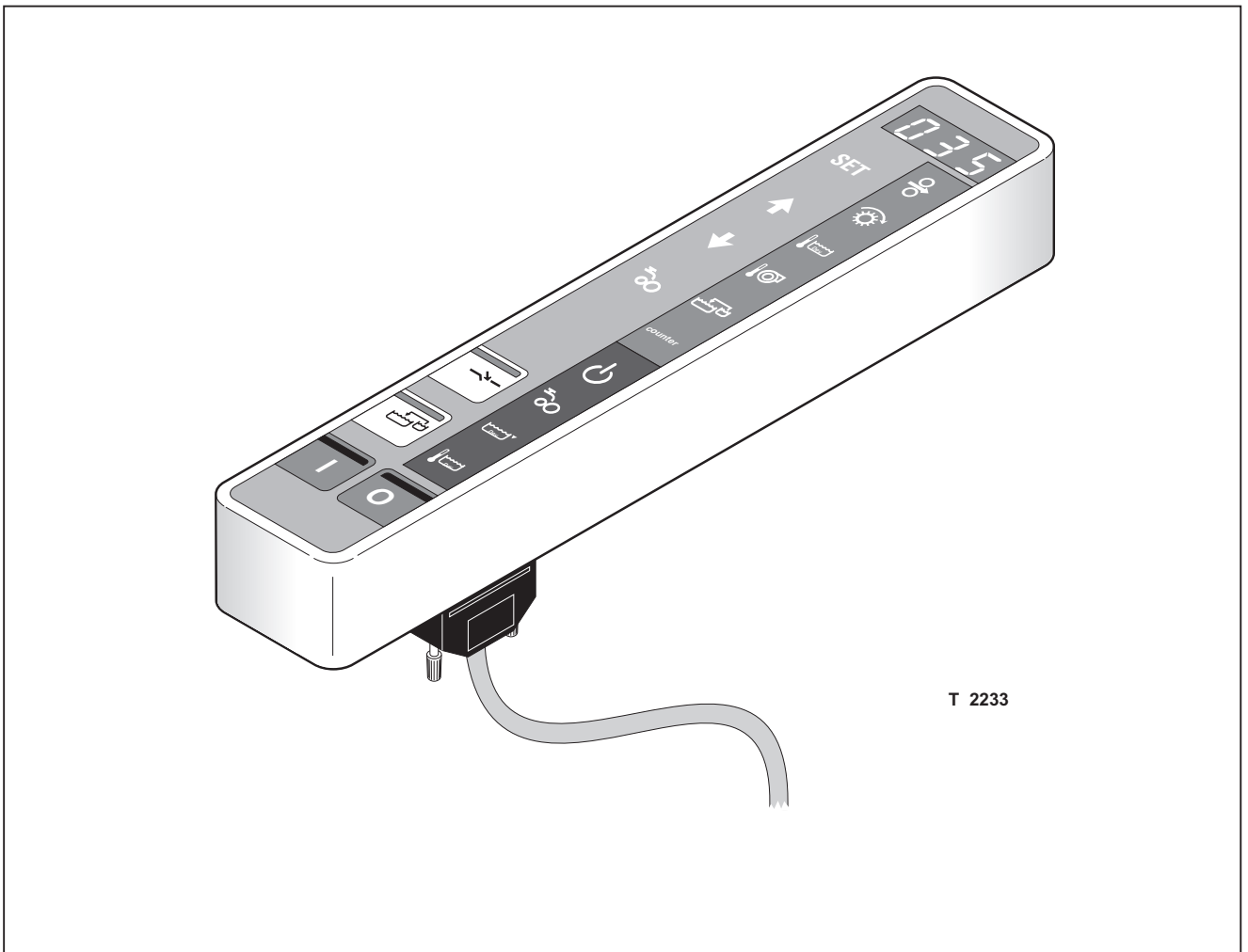

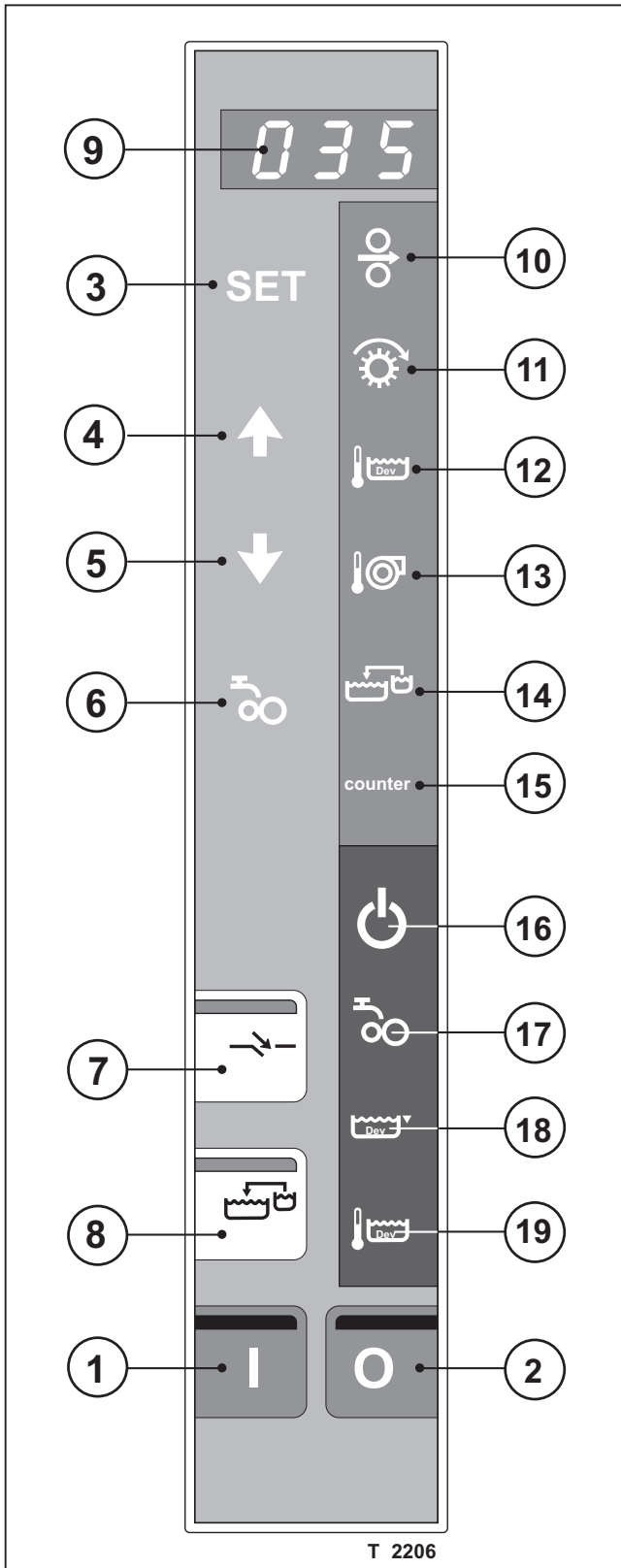

CONTROL PANEL LIGHT

All light in the display and various lamps of the control box (except for the light in the green on-lamp) can be switched off, when working in a darkroom with very light sensitive material. To switch off the light change value in parameter 02 to 0. If it becomes necessary to change a processing parameter, the display light will come on when pushing one of the "SET"-buttons (3). 20 secs. after the new setting has been confirmed the light will turn off again.

NOTE! Even though display light has been switched off all error codes will be displayed and "REWASH" lamp (7) will turn on if rewash is started.

FUNCTIONAL DESCRIPTION

ON-BUTTON (1)

(Lamp built-in).

Switches the processor from "OFF" mode into "STANDBY" mode provided that the main switch in the electronics drawer is switched on. When processor is in "STANDBY" or any other mode except for the "OFF" mode, the built-in lamp is lit.

OFF-BUTTON (2)

(Lamp built-in).

This button switches the machine from "STANDBY" mode into "OFF" mode. When the processor is in "OFF" mode only the built-in lamp is lit.

"SET" BUTTON (3)

Use "SET" button to

- **Change parameter values:**
The indicator for the selected processing parameter (10-15) is lit. Use the selection buttons (4) and (5) to select the processing parameter in which the value has to be changed. Push the "SET" button and the selected processing parameter indicator (10-15) will start to flash. Adjust the value using the selection buttons (4) and (5) and push the "SET" button again to confirm the new setting.
- **Reset the replenish container level function:**
See explanation for the "REPLENISHMENT" button (8).

SELECTION BUTTONS (4) & (5)

Use the selection buttons to

- **Select a processing parameter to be displayed or changed:**
The indicator for the selected processing parameter (10-15) will light up.
- **Change a processing parameter value:**
Use the buttons to increase or decrease the value.

See also description for "SET" button (3).

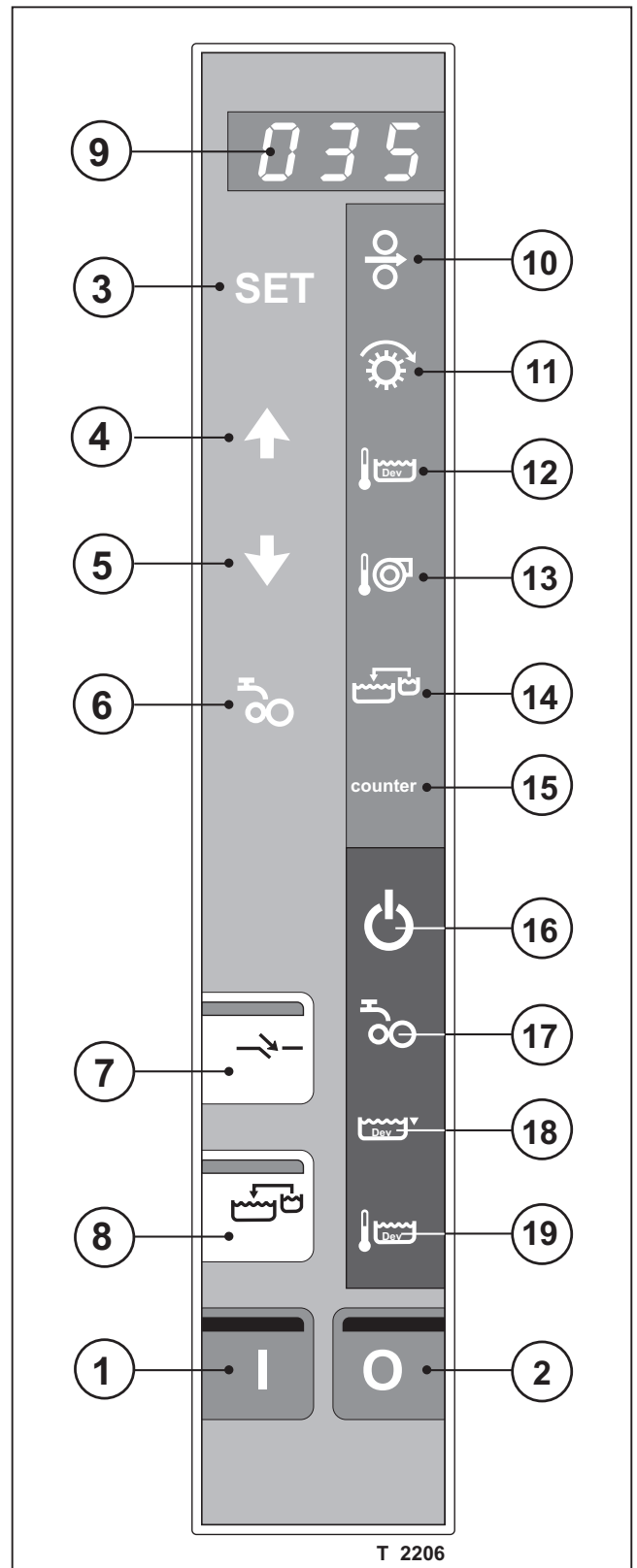

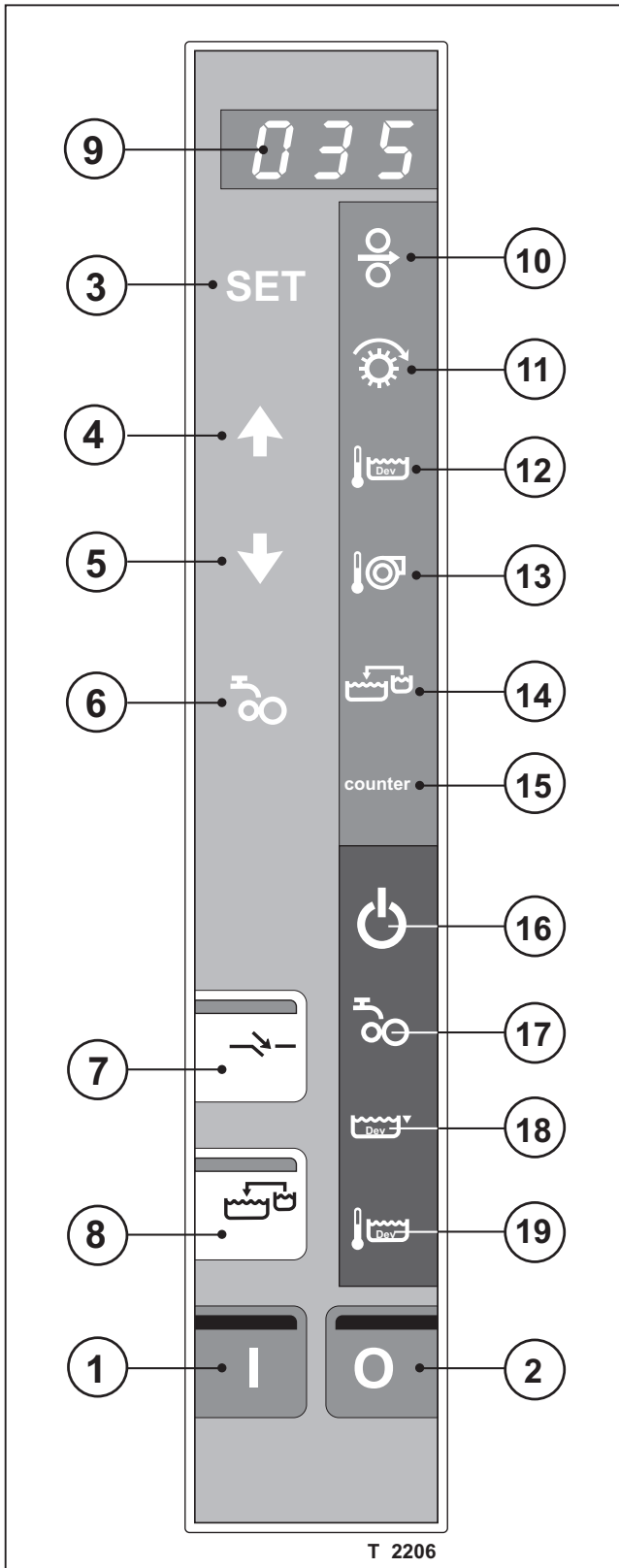

"GUM-RINSE" BUTTON (6)

Push the button and hold it for 3 secs. The "GUM-RINSE" program will start, the "GUM-RINSE" lamp (17) and the "WAIT" indicator (16) will start to flash asynchronously, which means that the "WAIT" indicator is on when the "GUM-RINSE" lamp is off and opposite. The rest of the control panel lamps and indicators are off except for the "ON" lamp (1). The display will show either "- A -" or "- O -" which are codes for the Auto-start function. See description of this function later in this chapter. When the rinsing part of the program is finished the "ON" lamp (1) turns off and the "OFF" lamp (2) starts to flash indicating that the gum section is being emptied. After a few minutes the processor automatically switches to "OFF" mode.

During gum-rinse when an input sensor is activated the transport mechanism stops to prevent that any material is fed into the processor.

"REWASH" BUTTON (7)

To start the "REWASH" function push the "REWASH" button twice. First push will stop the transport rollers and the built-in lamp will start to flash. Within the next 60 secs. the operator can carefully insert the plate into the "REWASH" slot. Second push will start all wash-off, gumming and dryer functions and the built-in lamp will be lit constantly together with the "WAIT" indicator (16). If the "REWASH" button is not pushed for the second time within the 60 secs. the processor will automatically return to "STANDBY" mode. The processor returns to "STANDBY" mode either automatically (time-out) after the plate has left it or manually when "REWASH" button is pushed for 2 secs.

NOTE! The above described procedure must be performed for each plate that is entered for rewashing and regumming. This is to reset the timer function.

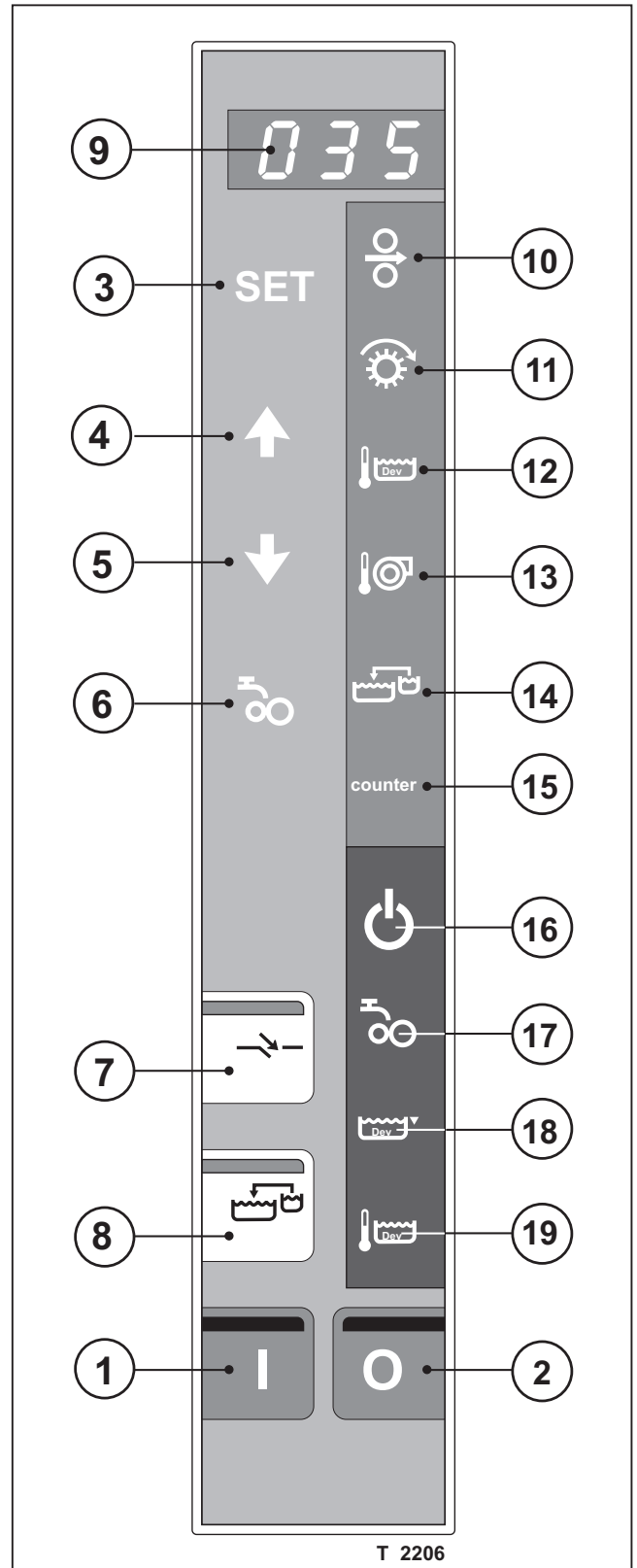

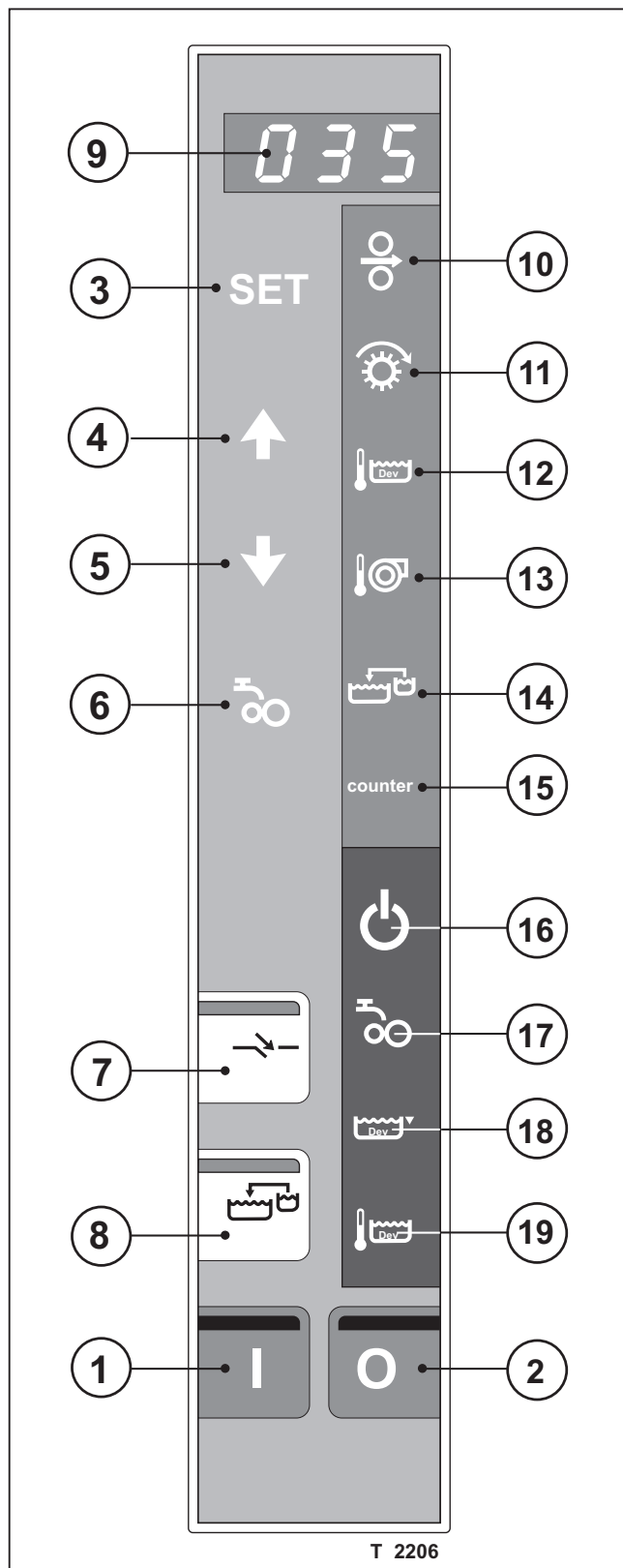

"REPLENISHMENT" BUTTON (8)

Use this button to

- **Manually top up the developer and wash-off section with fresh solution:**

While the pump runs the built-in lamp in the button will be lit. If pumps have been started manually the pumps will stop again when pushing the button.

- **Reset the container level function:**

Push the "REPLENISHMENT" button (8) on the control panel and hold it for 3 secs.

The display will change to show either "1 _ _" or "1 - -" indicating the status (empty/not empty) of the developer replenishment container.

Reset the container status to "1 - -" (full) by pushing "SET" button (3) once.

If status is "1 - -" before resetting, the display will change to "1 _ _" and then to "1 - -" again to confirm resetting.

Push "REPLENISHMENT" button again and the display will change to show either "2 _ _" or "2 - -" indicating the status (empty/not empty) of the wash-off replenishment container.

Reset the container status to "2 - -" (full) by pushing "SET" button (3) once.

Push the "REPLENISHMENT" button (8) to exit the function.

If low level is detected in the developer or wash-off sections the automatic replenishment system will automatically start the respective replenishment pump to re-establish the correct level. While the pump(s) run the built-in lamp will be lit.

NOTE! If a section is empty, it should be filled from suitable containers as it is quite time-consuming to fill it using the pump.

DIGITAL DISPLAY (9)

The display will show

- **Values for the different functions:**
During process the display will always show the set value for the default processing parameter. If another function has been selected, the display returns to show the default processing parameter shortly after. The default processing parameter is selected in set-up parameter 03.
- **Error-codes/Auto-start codes:**
See detailed description later in this chapter.

PLATE SPEED (10)

Indicator for plate speed function.

When selected the displays shows the set plate speed in cm/min. (inch/min.).

BRUSH SPEED (11)

Indicator for brush speed function.

When selected the displays shows the set brush speed in rpm.

DEVELOPER TEMPERATURE (12)

Indicator for developer temperature function.

When selected the displays shows the set developer temperature in °C (°F).

DRYER TEMPERATURE (13)

Indicator for dryer temperature function.

When selected the displays shows the set dryer temperature in °C (°F).

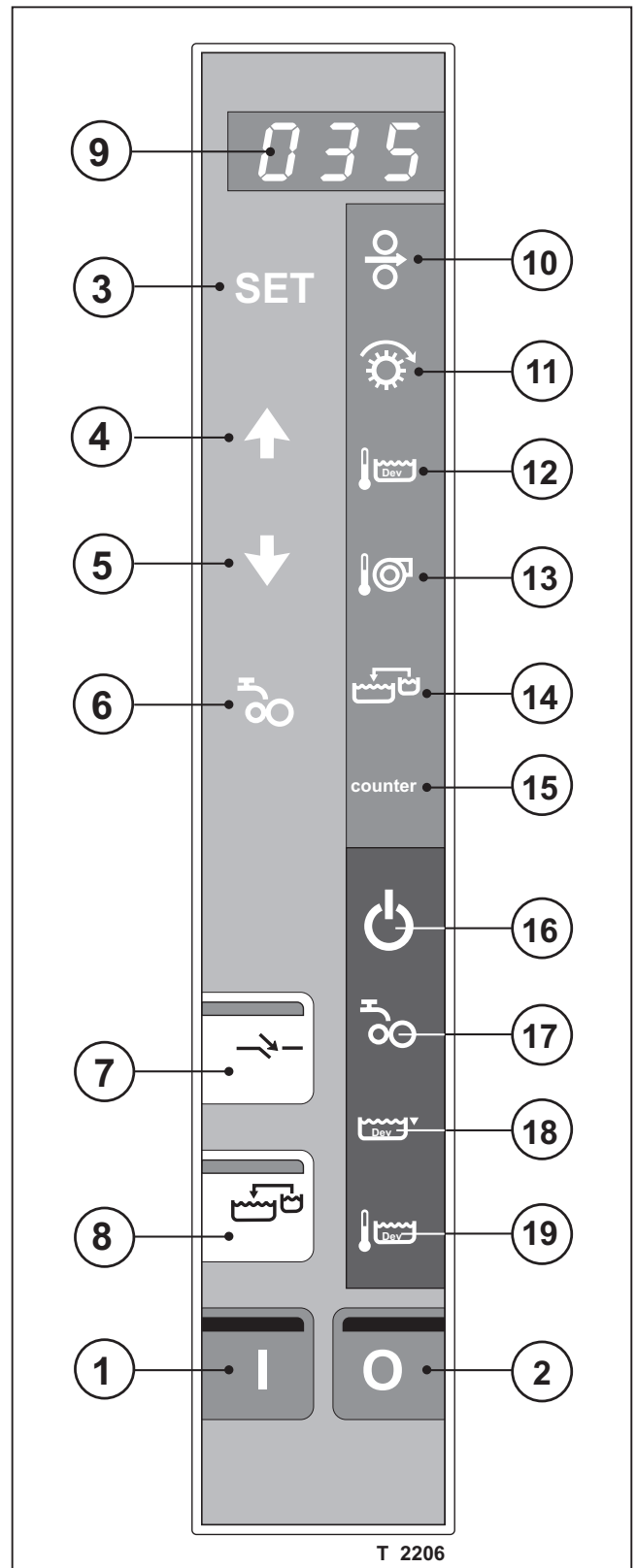

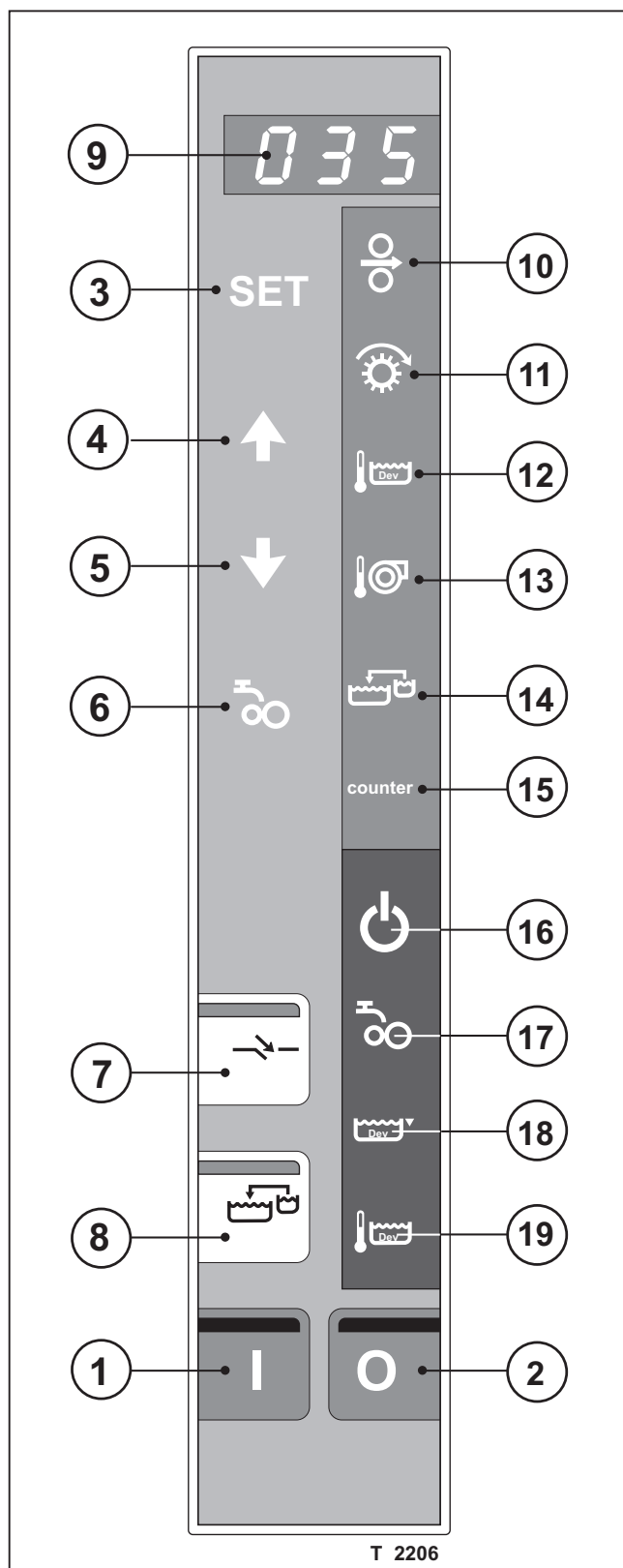

DEV/WASH-OFF REPLENISHMENT (14)

Indicator for the replenishment function.

When selected the display shows the set plate width in cm (inch).

Use this function together with the set-up parameters 32 and 50 to obtain the best and necessary replenishment.

COUNTER (15)

The counter function makes it possible to check the number of jobs processed in the machine, as it counts every activation of the input sensor(s).

The "SET" button (3) resets the counter, but only when the counter function has been selected using the SELECTION buttons (4 & 5) (indicator lit).

Use the value in PAR 05 to select the display factor for the counter.

"WAIT" (16)

This indicator is lit if any of the following situations occur:

- Replenishment container error.
Also a beeper will sound for 10 secs. and the display will show "- 2 -".
- Low level in DEV section.
Also the "LOW LEVEL" indicator (18) will be lit and the display will show "- 3 -".
- DEV temperature out of range.
Also the "DEV. TEMP." indicator (19) will be lit. The display will show "- 4 -".
- Low level in WASH-OFF 1 section.
The display will show "- 5 -".
- WASH-OFF 1 temperature out of range.
The display will show "- 6 -".
- WASH-OFF filters blocked.
The display will show "- 7 -" and a beeper will sound.
- Processor in "REWASH" mode.
The "REWASH" lamp (7) will also be lit.
- Input sensor(s) activated.

and it **flashes** (asynchronously with "GUM-RINSE" lamp (17)) when

- Processor runs in "GUM-RINSE" mode.

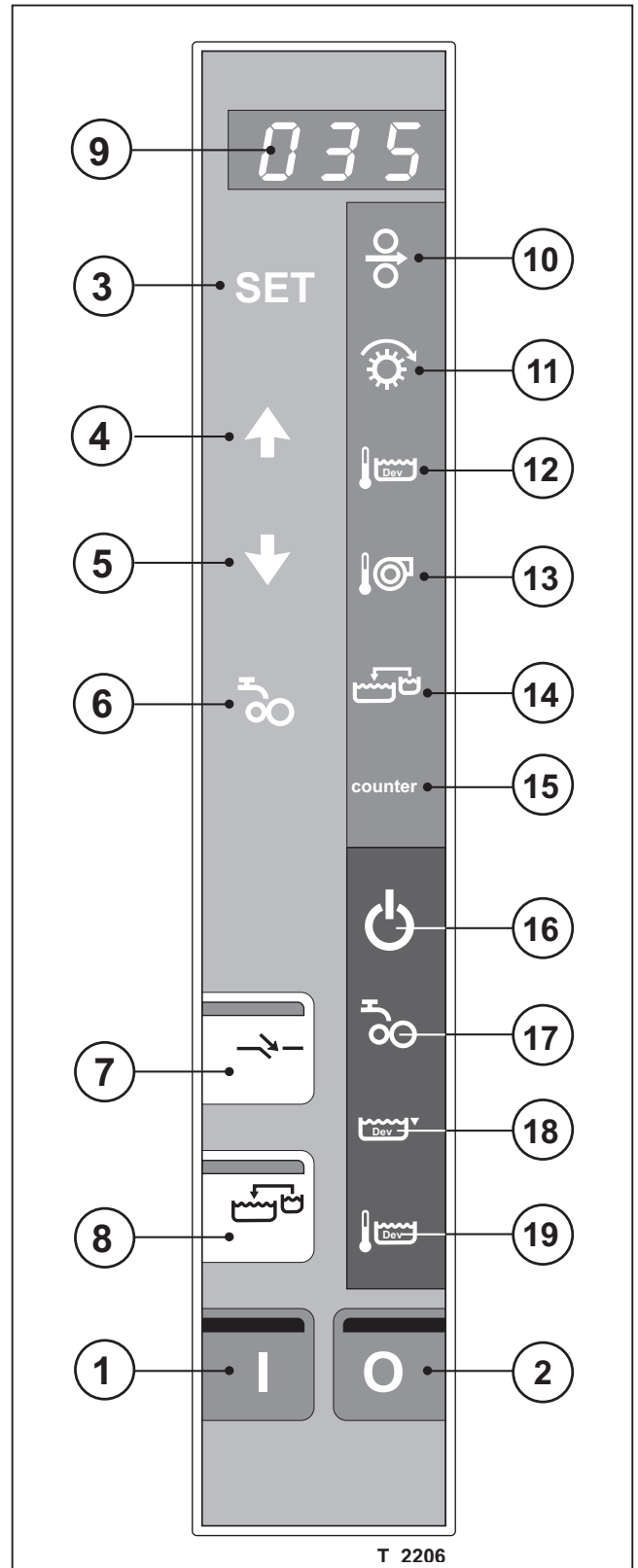

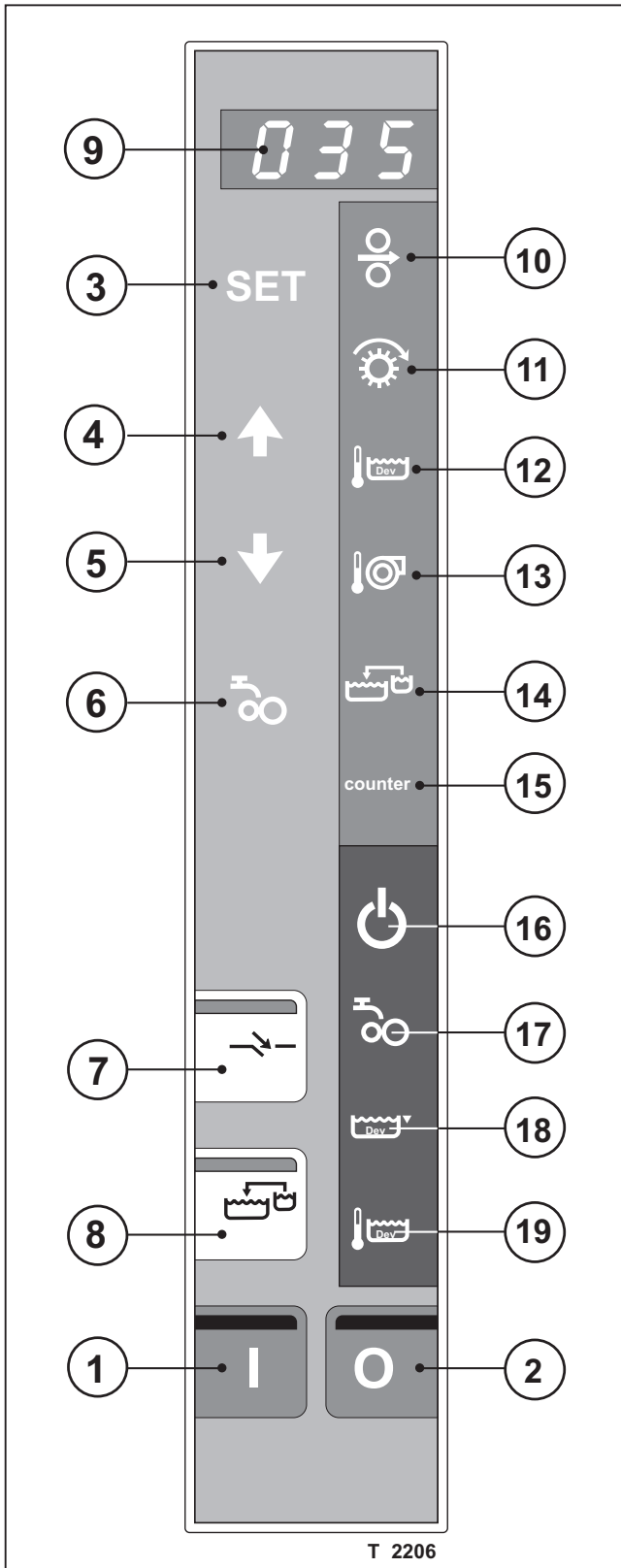

"GUM RINSE" (17)

This indicator flashes (asynchronously with "WAIT" indicator (16)) when processor is in "GUM-RINSE" mode.

"LOW LEVEL" (18)

If low level is detected in the developer bath, this indicator is lit.

If automatic replenishment has been selected (PAR 37) the replenishment pump automatically starts to re-establish the correct level. Otherwise top up to correct level manually by pressing the "REPLENISHMENT" button (8).

The circulation pump and the heating element automatically switch off until the correct level has been re-established.

NOTE! If the developer bath is empty and has to be filled, do this from a suitable container as it is quite time-consuming to fill the tank by using the replenishment pump.

"DEV. TEMP." (19)

This indicator is lit if the temperature in the developer bath is out of range; 'out of range' means that the actual temperature in the bath is ex. 2°C higher or lower than the preset value (PAR 36).

ERROR/AUTO-START CODES

Various codes can be displayed on the control panel display (9):

ERROR CODES:

- **1 - Tacho error on transport motor.**
Will appear for 5 secs. at each input sensor activation.
- **2 - Replenishment container error.**
Also a beeper sounds for 10 secs. And "WAIT" indicator (16) is lit.
- **3 - Low level, DEV section.**
"LOW LEVEL" indicator (18) and "WAIT" indicator (16) are lit.
- **4 - Developer temperature out of range.**
"DEV. TEMP." indicator (19) and "WAIT" indicator (16) are also lit.
- **5 - Low level, WASH-OFF 1 section.**
"WAIT" indicator (16) is lit.
- **6 - WASH-OFF temp. out of range.**
"WAIT" indicator (16) is lit.
- **7 - WASH-OFF circulation filters blocked.**
"WAIT" indicator (16) is lit and a beeper will sound.
Will appear for 10 secs. at the start of each processing cycle.
- **8 - Plate jam error.**
Only for on-line processors (PAR 10 setting 01-08).

AUTO-START CODES:

- **A - Auto-start switched on.**
- **O - Auto-start switched off.**

See how to use the Auto-start function in chapter 3 - "SHUTDOWN PROCEDURE" later in this manual.

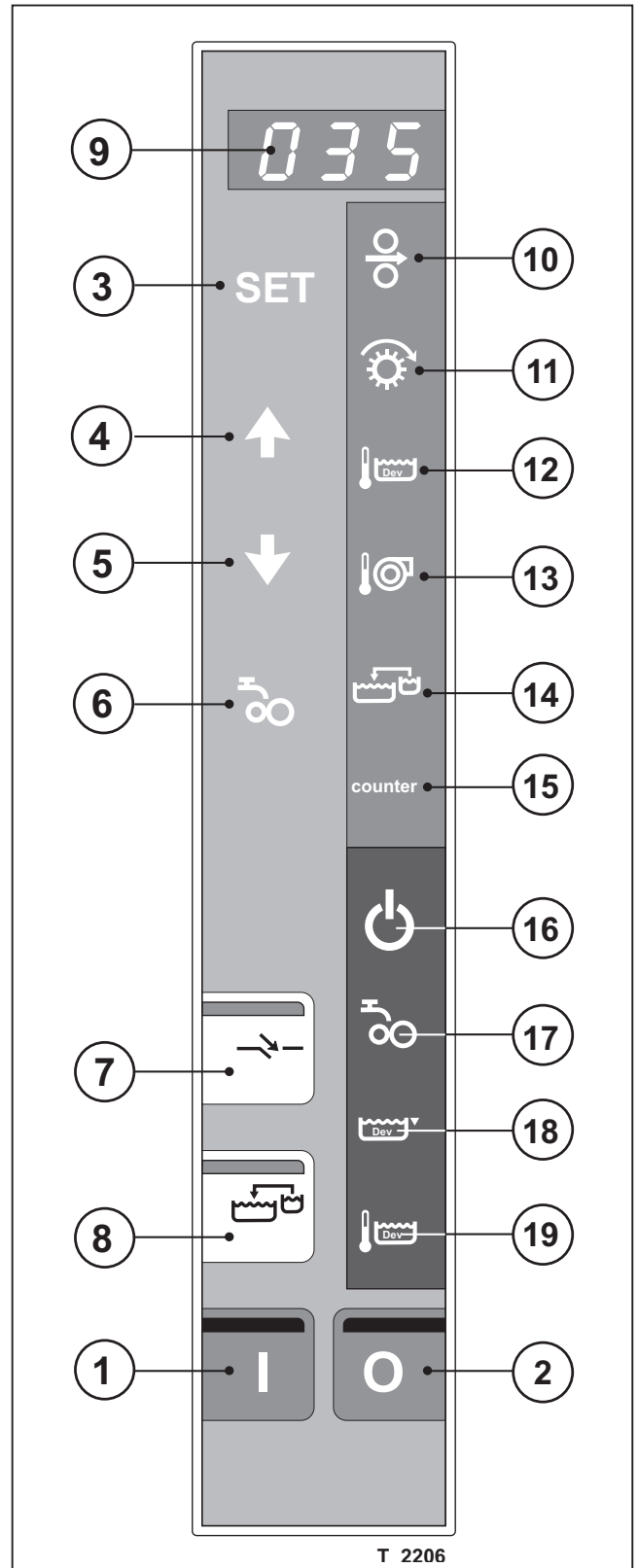

- GB -

3. OPERATING PROCEDURES

On the following pages are described the operating procedures as well as the different adjusting procedures.

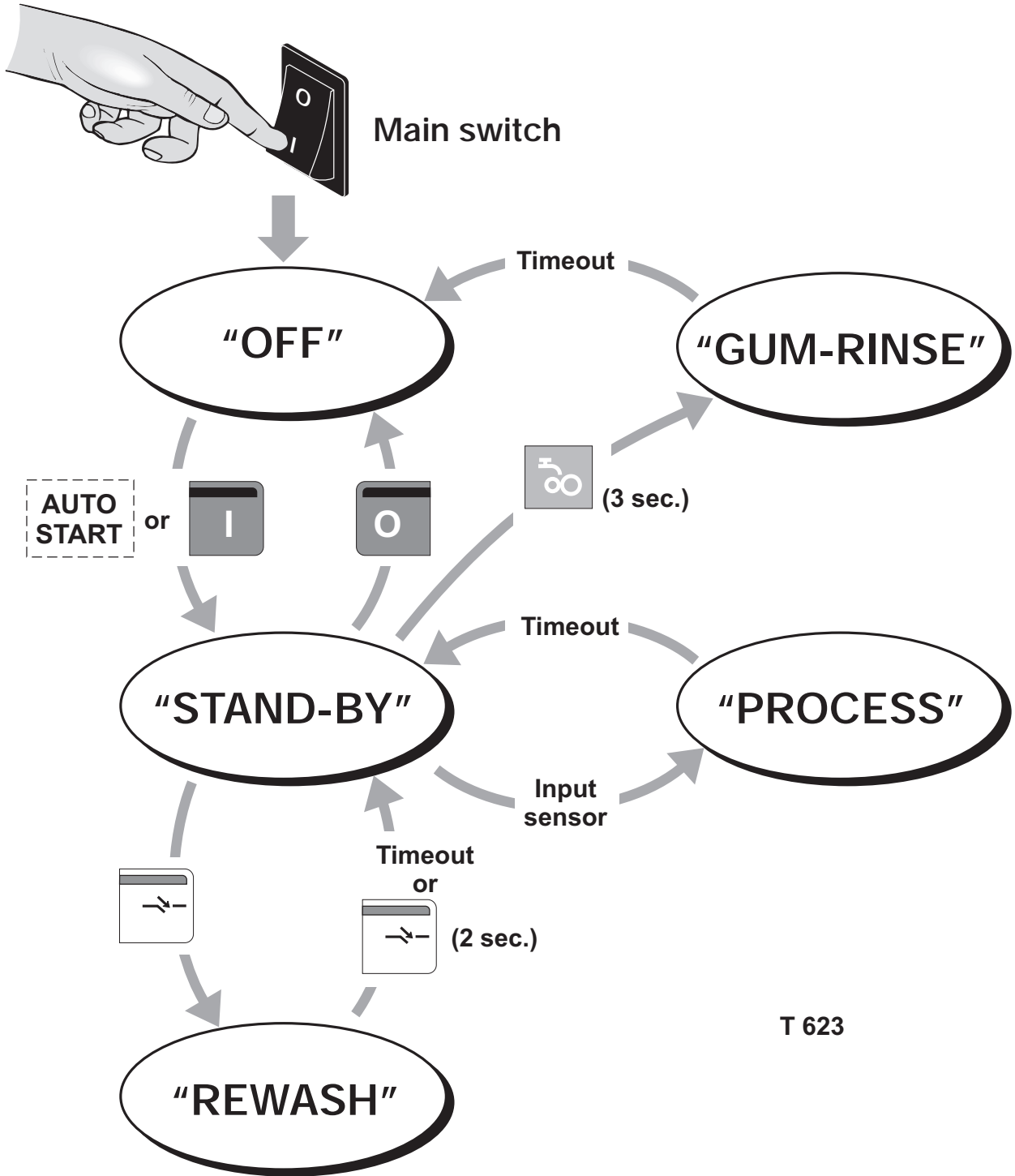

OPERATING MODES

(See illustration opposite).

The processor can be in one of 5 different modes **"OFF"** mode, **"STAND-BY"** mode, **"PROCESS"** mode, **"REWASH"** mode and **"GUM-RINSE"** mode.

Please refer to chapter 2 - CONTROLS AND INDICATORS for more detailed descriptions of the various lamps and buttons mentioned in the following.

"OFF" MODE

When the main switch is switched on, the processor is automatically in **"OFF"** mode:

- Power is on to the processor.
- All functions are off.
- The lamp in the "OFF" button is lit.
- If value in PAR 04 - "Operation mode" is set to 1 (test) the test-program is active.

"STAND-BY" MODE

Pushing the "ON" button switches the processor into "STAND-BY" mode:

- The lamp in the "ON" button is lit.
- Developer temperature control and circulation is on.
- Wash-off temperature control and circulation is on.
- Transport motor runs idle.
- All processing parameters are adjustable.
- If value in PAR 08 - "Anti-crystallisation" is set to 1 this function is active.

"PROCESS" MODE

Activating an input sensor makes the processor switch from "STAND-BY" mode into "PROCESS" mode (see also description in "PROCESSING FROM THE FEED TABLE" later in this chapter).

- Transport motor switches to set transport speed.
- Dryer temperature control and blower is on.
- The brush and the various spray pumps start delayed just before the plate enters the respective sections.
- During processing the processing parameters are adjustable.
- The developer- and wash-off replenishment pumps adds replenishment to the sections as set in the specific parameters.
- The processor automatically returns to "STAND-BY" mode shortly after the plate exits.

"REWASH" MODE

(Only from STAND-BY).

(See also more detailed description in "USING THE REWASH SLOT" later in this chapter).

Pushing the "REWASH" button on the control panel twice switches the processor into "REWASH" mode:

- First push will stop the transport rollers. Within the next 60 secs. the operator must insert the plate into the "REWASH" slot.
- Second push will start all wash-off, gumming and dryer functions.
- The processor returns to "STAND-BY" mode either automatically (time-out) after the plate has left it or if "REWASH" button is pushed for 2 secs.

continues.....

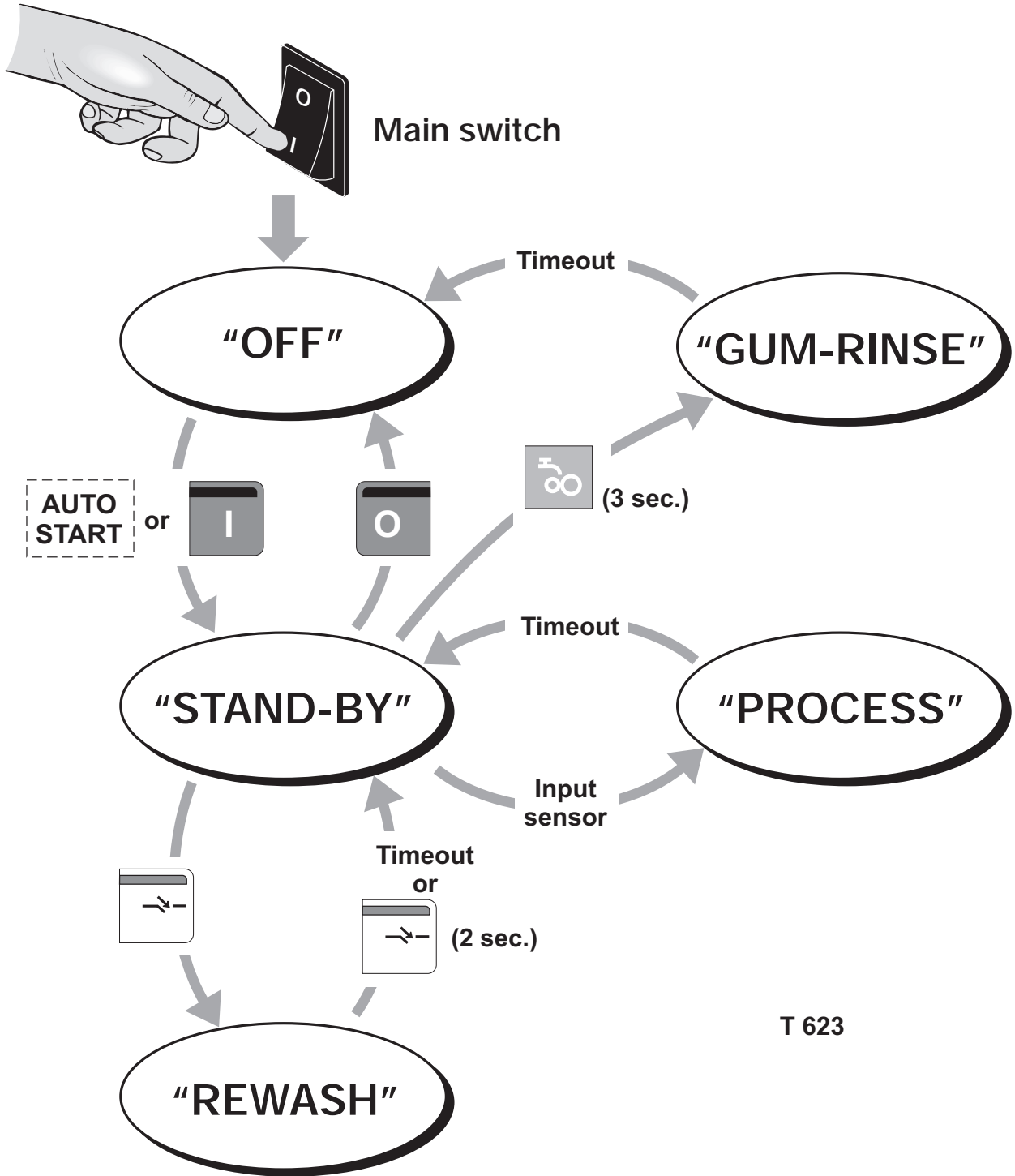

"GUM-RINSE" MODE

(Only from STAND-BY).

(See also more detailed description in "RUNNING THE GUM-RINSE PROGRAM" in chapter 4 later in this manual).

- Push the "GUM-RINSE" button for min. 3 secs. to start the "GUM-RINSE" program.
- During the rinse program the control panel cannot be used except for the "OFF" button.
- When the rinse program is finished the processor automatically switches to "OFF" mode.

AUTO-START

When the processor is turned off on the OFF-button or when starting the "GUM-RINSE" program it can be selected whether or not you want the processor to start-up automatically the next day.

(See how in "SHUTDOWN PROCEDURE" later in this chapter).

When selected the processor automatically switches from "OFF" mode into "STAND-BY" mode at a preset time.

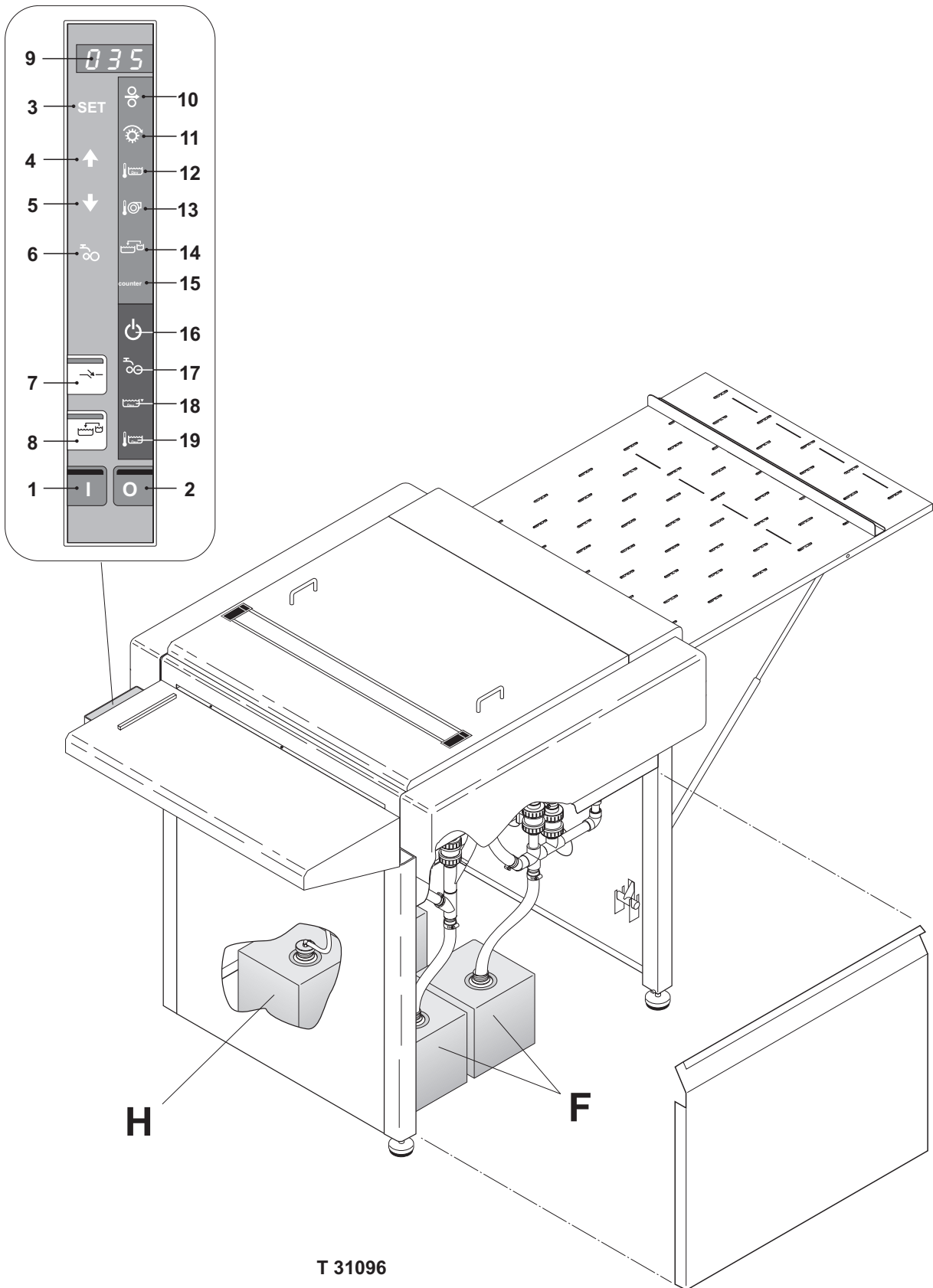

T 31096

DAILY START-UP

(See illustration opposite).

NOTE! Before starting always make sure, that the containers for waste developer and wash-off solution (F) are empty.

NOTE! Check that the containers for developer and wash-off replenishment, gum and biocide (option) (H) are sufficiently filled.

- If processor is not already started (AUTO-start) push the ON-button **(1)** and verify that the built-in lamp is lit.
The processor is now in "STAND-BY" mode with the rollers idling.
- Make appropriate processing parameter adjustments if necessary.
- The "WAIT" indicator **(16)** will be lit until all levels and temperatures are correctly established.
- When the "WAIT" indicator turns off, the processor is ready for use.

SETTING THE PROCESSING PARAMETERS

(See illustration opposite).

- Use selection buttons **(4)** and **(5)** to select the processing parameter(s) you want to change:

(10) Plate speed	(104) (50 - 240
cm/min)	
(11) Brush speed	(100) (40 - 120 rpm)
(12) Dev. temp.	(22) (15 - 45 °C)
(13) Dryer temp.	(60) (30 - 65 °C)
(14) Dev. Repl.	(65) (0 - 88 cm)

(The first set of numbers are the default settings).

The setting value for the Dev. Repl. **(14)** should be the width of the plate (in cm) to be processed. The processor measures the plate length when processing and then uses the set plate width to calculate the plate area. The replenishment rate (ml/m plate) is set in PAR 32.

- To change f.ex. the brush speed push selection button **(4)** or **(5)** until "Brush speed" indicator **(11)** is lit.
The current setting is shown in the display **(9)**.
- Push "SET" button **(3)**.
The "Brush speed" indicator **(11)** will start to flash indicating that it is now possible to adjust the value.
- Use selection buttons **(4)** and **(5)** to change the value and then push "SET" button **(3)** to confirm the new setting.
- Repeat procedure for each parameter you want to change.

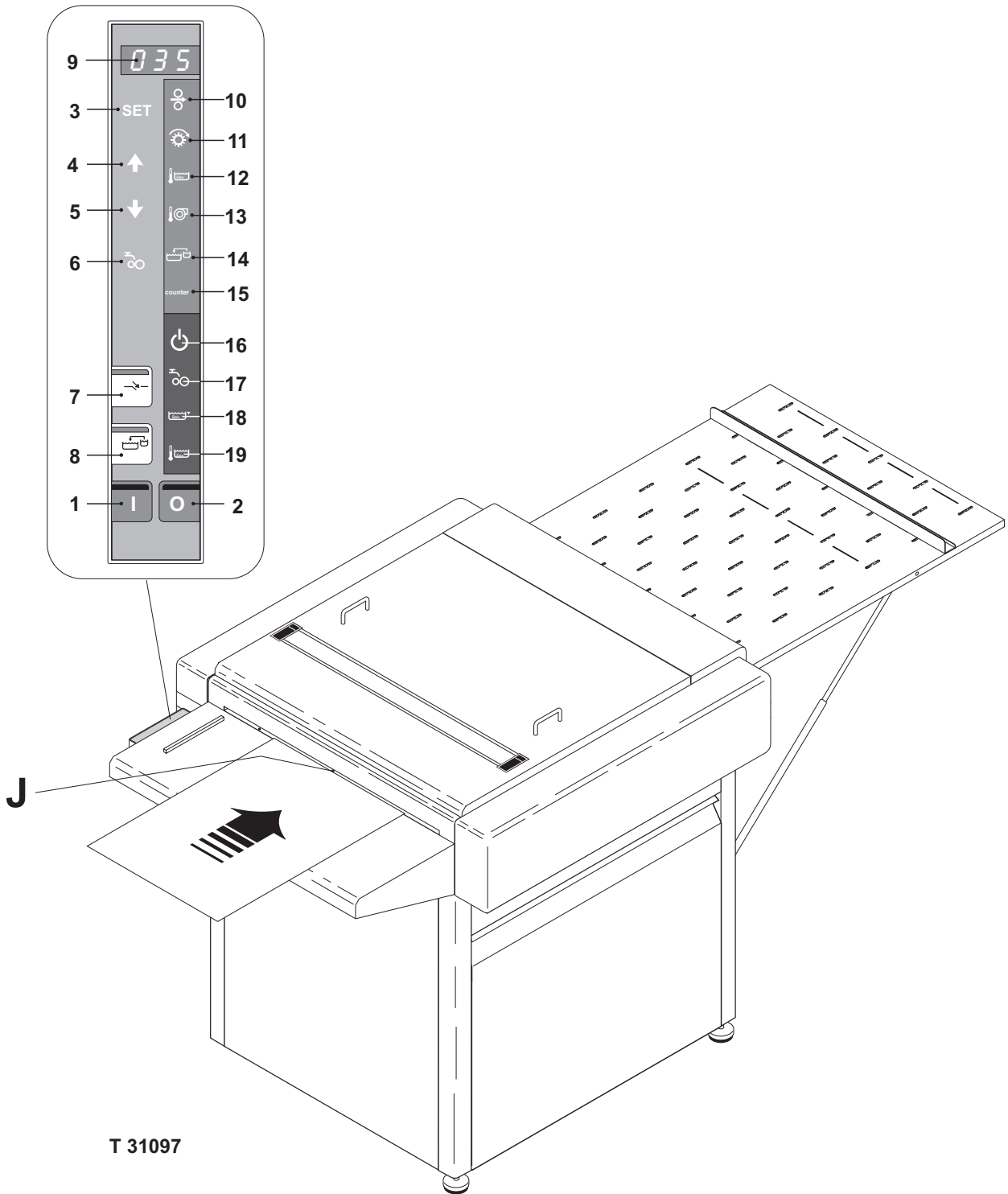

PROCESSING FROM THE FEED TABLE

Only off-line processors.

(See illustration opposite).

- The processor must be in "STAND-BY" mode.
- Always feed plate material from the middle of the feed table with the emulsion side upwards.
- Feed the plate slowly into the processor until it engages the entrance rollers.

The input sensor(s) **(J)** switch(es) the processor into "PROCESS" mode and the machine starts up with the preset speed and temperature values.

If control panel light is ON:

- Verify that the "WAIT" indicator **(16)** is lit, indicating that a plate is being fed into the machine.
- The "WAIT" indicator turns off shortly after the plate has left the input sensor(s). A new plate can then be inserted.
- The machine returns to "STAND-BY" mode shortly after the plate has left the dryer section.

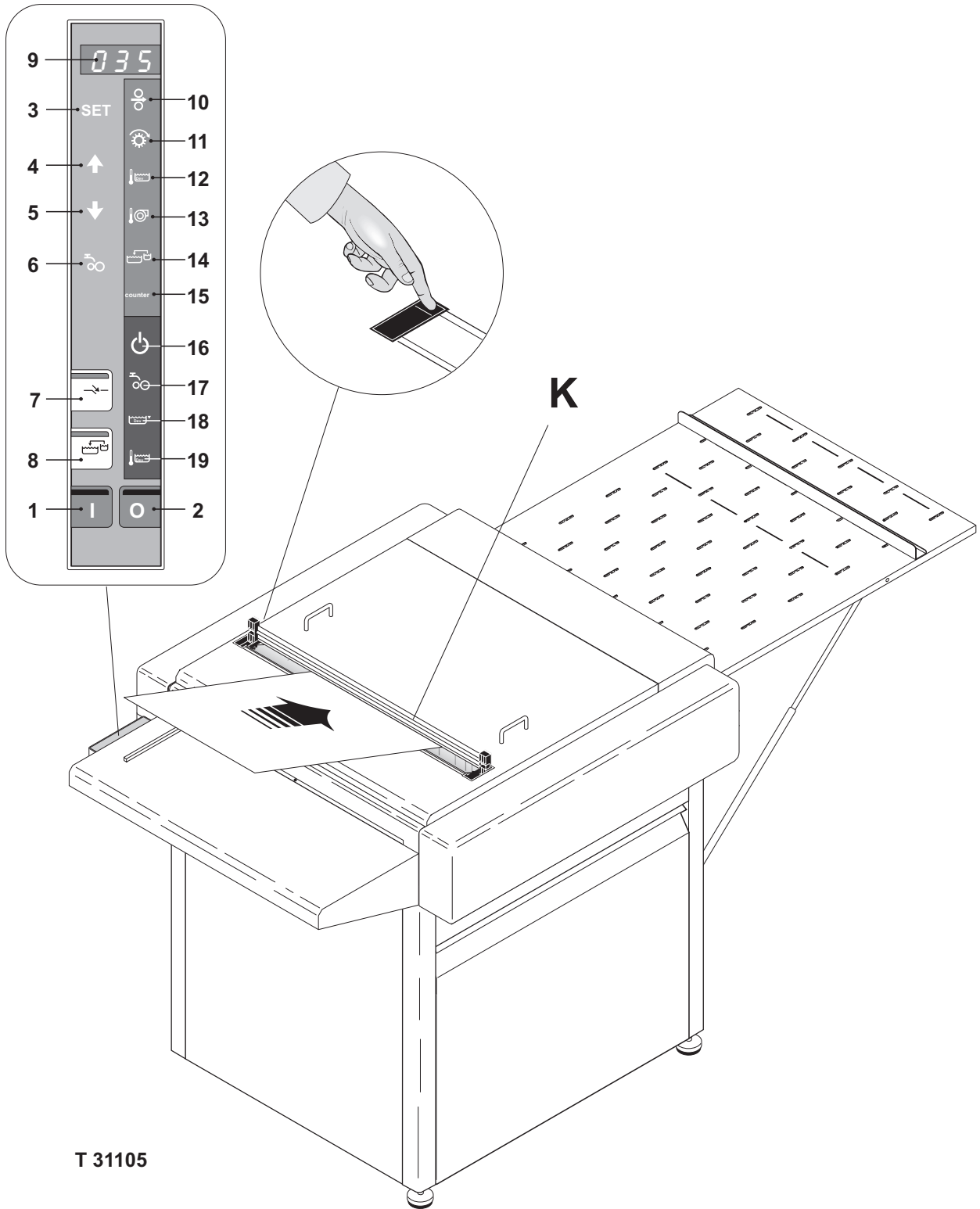

T 31105

USING THE "REWASH" SLOT

(See illustration opposite).

- Machine must be in "STAND-BY" mode (switched on by the ON-button **(1)**).
- Open the "REWASH" lid **(K)** by pushing down as illustrated.
- Push the "REWASH" button **(7)**.
The built-in lamp is lit, the "WAIT" indicator **(16)** will start to flash and if transport rollers run idle they stop.
- Insert the plate into the "REWASH" slot with the emulsion side upwards until it hits the transport rollers.
- Press the "REWASH" button **(7)** again.
The transport rollers start to turn and the wash-off, gum and dryer functions start while the developer functions remain in "STAND-BY".

NOTE! If "REWASH" button (7) is not pushed for the second time within 60 secs. the processor automatically returns to "STAND-BY" mode.

- When the plate has left the "REWASH" slot close the lid **(K)** again.

- The "REWASH" program ends (processor returns to "STAND-BY") shortly after the plate has left the dryer section.
The "REWASH" lamp **(7)** and the "WAIT" indicator **(16)** turn off.

NOTE! The "REWASH" procedure must be executed as described above for each plate that is entered for rewashing and regumming. This is to reset the timer function.

- To exit the "REWASH" program manually push the "REWASH" button **(7)** for 2 secs. until the built-in lamp and the "WAIT" indicator **(16)** turn off.
The processor stops and returns to "STAND-BY" mode.

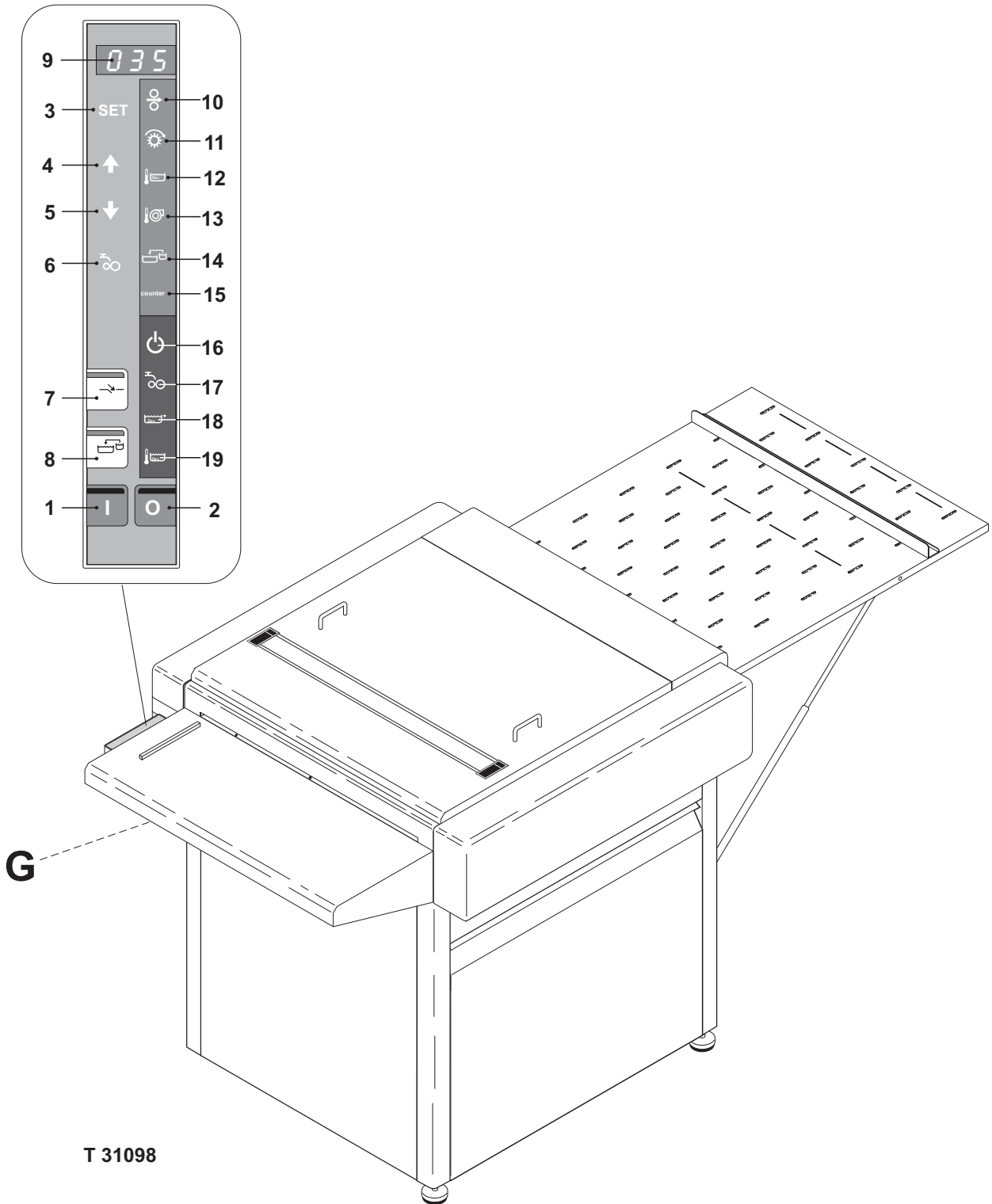

SHUTDOWN PROCEDURE

NORMAL SHUTDOWN

- The processor should be in “STAND-BY” mode.
- There are two ways to shut the processor down:

- Run the “GUM-RINSE” program (see how in “CLEANING, GUM SECTION”) later in this manual.

The processor automatically shuts down at the end of the “GUM-RINSE” program.

- Turn off the processor on the “OFF” button **(2)**.

The display will show the current code for the Auto-start function for 10 secs.:

- **A** - Auto-start switched on.
- **O** - Auto-start switched off.

Within the 10 secs. you can change the current code by pushing the “SET” button **(3)** and change the code by means of the selection buttons **(4)** or **(5)**. Push “SET” **(3)** again to confirm new setting.

The processor will turn off after app. 10 secs.

NOTE! When shutting the machine down without running the "GUM-RINSE" program always first push the "OFF" button on the control panel.

COMPLETE SHUTDOWN

NOTE! The processor should only be shut down completely for holidays or for maintenance and servicing purposes.

- Shutdown the processor as described under “NORMAL SHUTDOWN”.
- Turn the main switch **(G)** to "**O**" (**off**).

- GB -

4. CLEANING AND MAINTENANCE

GENERAL

Performing cleaning and maintenance regularly reduces the chances of equipment failure and the loss of processing quality.

Only one person should be responsible for performing the preventive maintenance program. That person should be familiar with the equipment as well as its operational characteristics and maintenance requirements.

The major clean-up procedure can be performed in two to four hours depending on the condition of the machine and on the proficiency of the person cleaning it.

NOTE! Personnel performing any maintenance, cleaning or servicing must familiarize themselves with the instructions described in the *Safety Instruction Manual* before attempting any of these procedures.

CAUTION! Do not cover the machine with a cloth or piece of plastic to protect it from dust, as this prevents free circulation around the machine and can lead to condensation and overheating.

CLEANING ACCESSORIES

CAUTION! Never use hard tools or abrasive materials when cleaning any part of the processor.

Apron, rubber gloves and eye goggles.

For personal protection.

Lint-free cloth, sponge and soft brush.

For cleaning of rollers, guides and tank walls.

Longhandled bottle brush and thin wire (ex. paper clip).

For cleaning the inside and the holes of the spray tubes.

CLEANING AGENTS

WARNING! Never use cleaning agents containing chlorinated solvents or acetic or phosphoric acid. These constitute a health hazard and could damage the processor.

Warm water 35-40°C (95-104°F).

For normal cleaning purposes and to rinse after using other cleaning agents.

Developer

For cleaning of developer section transport rollers.

Citric acid 10%/Nitric acid 5%

For major cleaning purposes.

Commercially available biocide/strong alkalic liquid

For cleaning off heavy algae-, fungal- or bacterial growth in the wash-off section.

BEARING BLOCKS

Most of the bearing blocks are fabricated with coarse chamfers in one end (see illustration). When a bearing has been removed from the processor for cleaning etc. it is very important for the correct function of the machine that this end is mounted downwards in the tank.

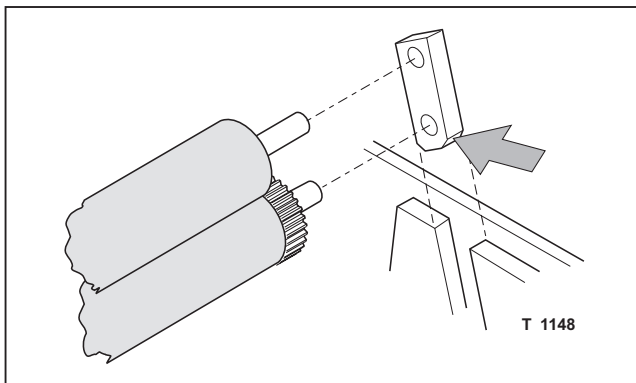

SPRAY TUBES

When a spray tube has been removed from the processor for cleaning or servicing purposes make sure to reinstall it properly:

(See illustration below)

- Insert the tube into the hole in the right tank side.
- Lower the spray tube into the groove in the left tank side pushing it all the way to the bottom of the groove making sure that the groove (1) in the spray tube fits onto the notch (2) in the bottom of the groove.

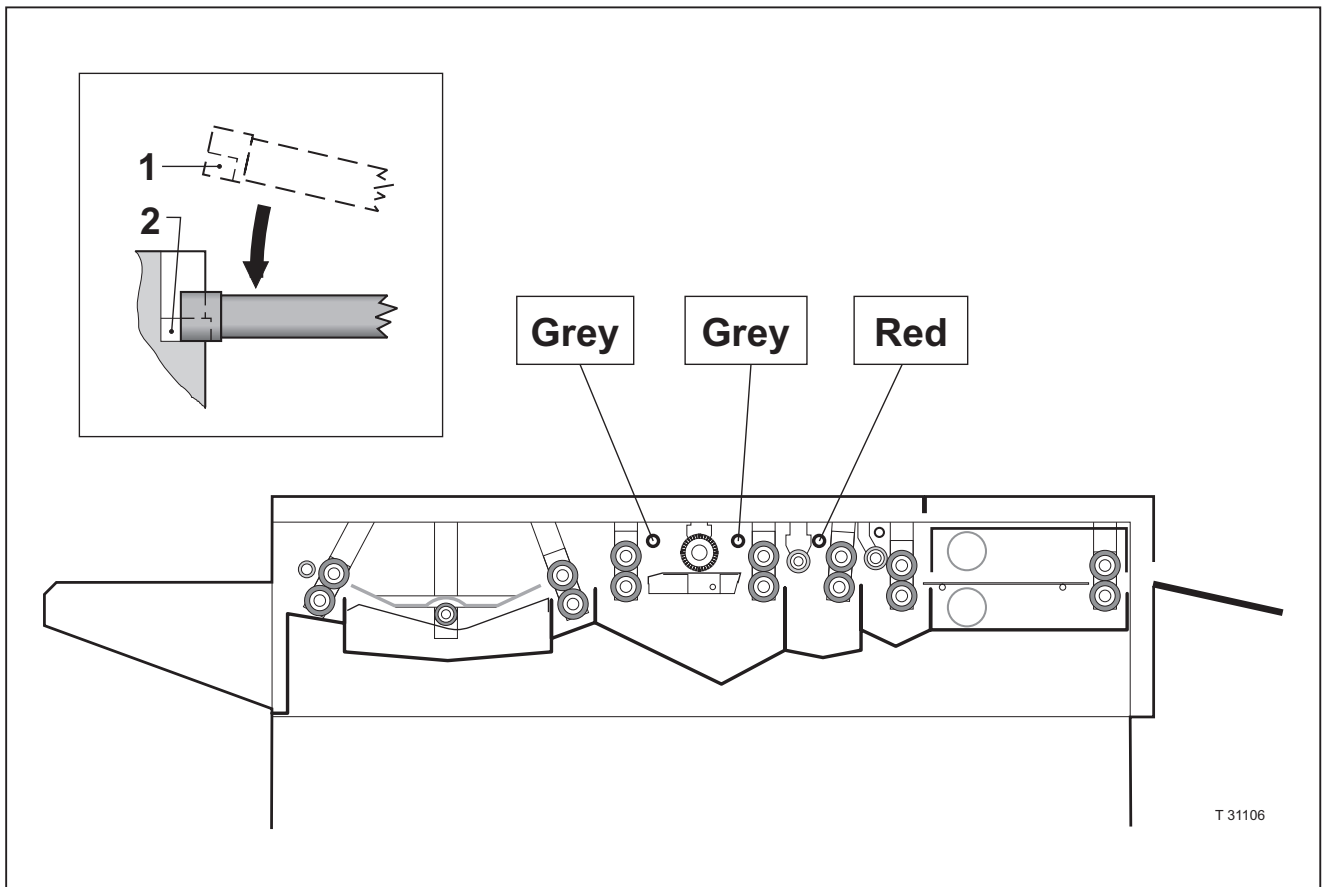

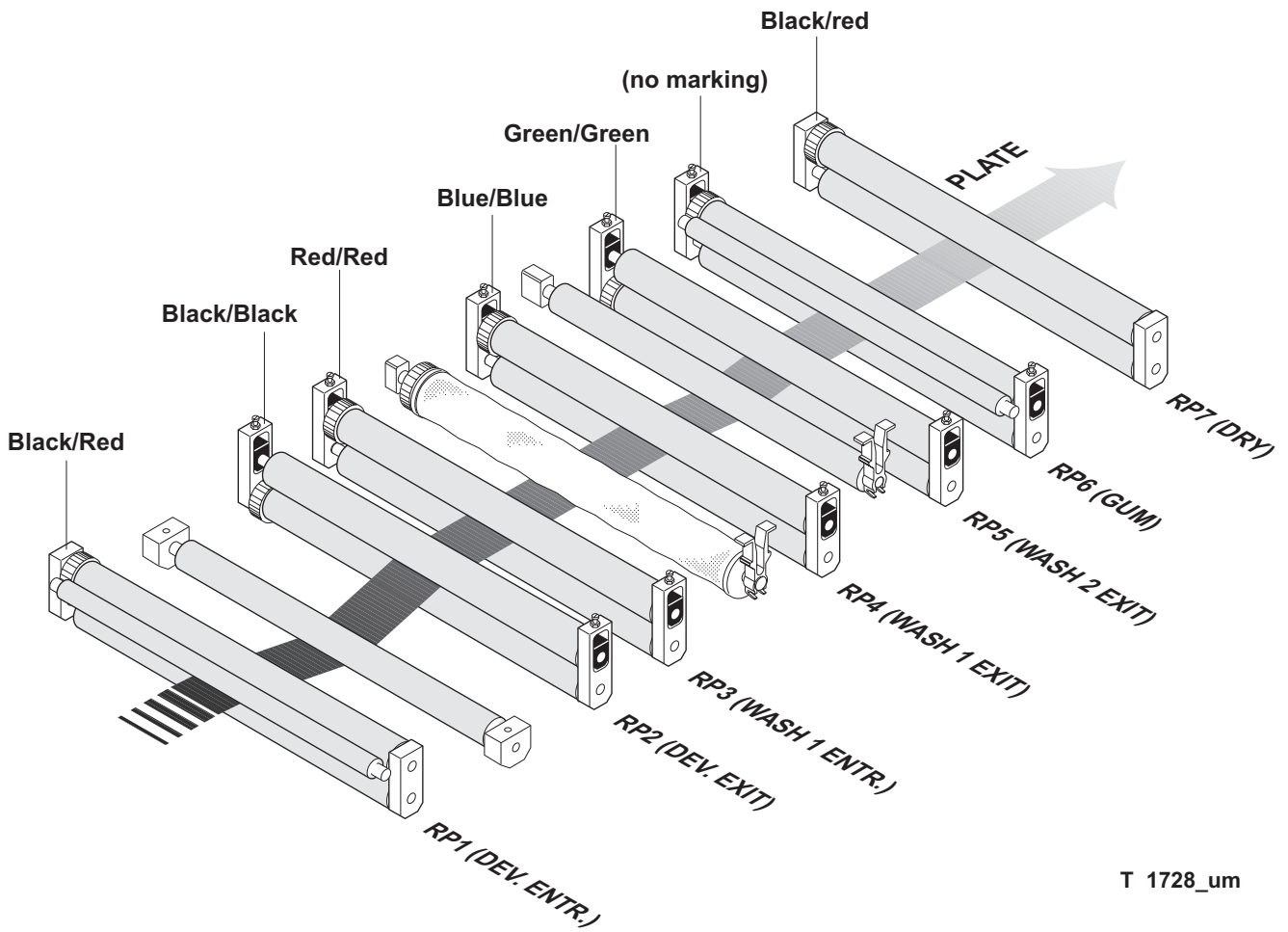
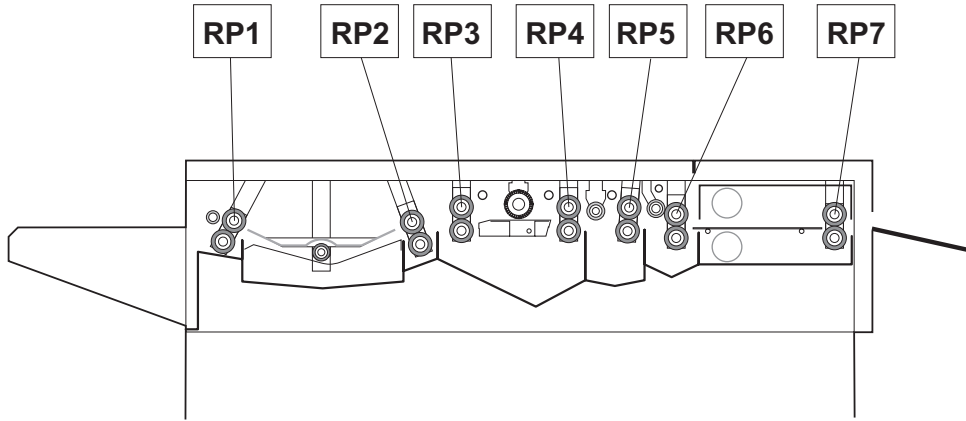

T 1728_um

IDENTIFICATION OF ROLLERS

(See illustration opposite).

The machine is equipped with 7 roller pairs (RP1-7). They are not all alike concerning roller-configuration or location of drive gear. When the rollers and bearings have been removed from the machine for cleaning etc. it is very important for the correct function of the machine that all parts are reinstalled in their proper place. For this purpose each roller pair (except RP6) has been marked with a combination of coloured o-rings on the rollers.

The correct configuration and location of the roller pairs are as described below and as shown on the illustration opposite.

RP1 (Dev. entrance): **(black/red)**
Bearings: Ordinary
Gear: On upper roller

RP2 (Dev. exit): **(black/black)**
Bearings: Adjustable
Gear: On lower roller

RP3 (Wash-off 1 entrance): **(red/red)**
Bearings: Adjustable
Gear: On upper roller

RP4 (Wash-off 1 exit): **(blue/blue)**
Bearings: Adjustable
Gear: On upper roller

RP5 (Wash-off 2 exit): **(green/green)**
Bearings: Adjustable
Gear: On lower roller

RP6 (Gum): **(no marking)**
Bearings: Adjustable
Gear: On upper roller

RP7 (Dry): **(black/red)**
Bearings: Ordinary
Gear: On upper roller

- GB -

CLEANING/MAINTENANCE INTERVALS

Refer to the table below for information about when and what to clean.

The cleaning and maintenance procedures are described on the following pages.

NOTE! Use table below as a guide. The cleaning intervals must always correspond to the duty level of the processor.

OPERATION	Daily	Weekly	Monthly	¼ yearly
GENERAL				
SAFETY CHECK, MECHANICAL	X			
CHECK CONTAINER CONTENTS		X		
CLEANING, PROCESSOR EXTERIOR				X
LUBRICATION, GEARS				X
CHANGING/CLEANING FILTERS				
DEVELOPER SECTION				
NORMAL CLEANING		X		
MAJOR CLEANING			X	
CHANGE DEVELOPER				
WASH-OFF SECTION				
MAJOR CLEANING			X	
CHANGE SOLUTION				
GUM SECTION				
NORMAL CLEANING	X			
MAJOR CLEANING		X		
DRYER SECTION				
NORMAL CLEANING	X			
<p>1) Filter change intervals: Developer filter: 1 month or after every 500 m plate processed. Wash-off filter: After every 150m plate processed.</p> <p>2) The solution should be changed regularly. (Refer to the material data sheets for intervals).</p>				

SAFETY CHECK

MECHANICAL

Check proper function/location of:

- Left/right fenders
- Top cover.
- Dryer covers.
- Cover, electronics drawer.

CHECK OF CONTAINER CONTENTS

Developer replenishment

Check that the container is sufficiently filled.
Refill or replace if necessary.

NOTE! After changing a container the container level function must be reset.

Wash-off replenishment

Check that the container is sufficiently filled.
Refill or replace if necessary.

NOTE! After changing a container the container level function must be reset.

Gum

Check that the container is sufficiently filled.
Refill or replace if necessary.
Replace gum if it is dirty, to thin or to thick.

Waste containers

Check that the waste containers are not almost full.
Empty or replace if necessary.

When one or more replenishment containers have been exchanged it is very important that the correct hoses are connected to them:

Developer replenishment:	Red hose
Wash-off replenishment:	Blue hose
Gum:	Clear hose

RESETTING OF THE CONTAINER LEVEL FUNCTION

When one or both of the developer or wash-off replenishment containers have been replaced with full containers the electronics has to be reset as described below:

- Push the “REPLENISHMENT” button **(8)** on the control panel and hold it for 3 secs.
- The display will change to show either “1 _ _” or “1 - -” indicating the status (empty/not empty) of the developer replenishment container.
- Reset the container status to “1 - -” (full) by pushing “SET” button **(3)** once.
If status is “1 - -” before resetting, the display will change to “1 _ _” and then to “1 - -” again to confirm resetting.
- Push “REPLENISHMENT” button again and the display will change to show either “2 _ _” or “2 - -” indicating the status (empty/not empty) of the wash-off replenishment container.
- Reset the container status to “2 - -” (full) by pushing “SET” button **(3)** once.
- Push the “REPLENISHMENT” button **(8)** to exit the function.

CLEANING, PROCESSOR EXTERIOR

Accessories:

- Lint free cloth

Cleaning agents:

- Warm water.

- Wipe clean all surfaces (especially the feed table and the exit table).

NOTE! Do not use any abrasive materials when cleaning the processor panels.

LUBRICATION, GEARS

- Lubricate all gears using Alu-grease.
(Type PAL TP 1054 or equivalent).

CHANGING/CLEANING OF FILTERS

Clean the filters regularly as described below:

(See illustration)

- Place the drip tray **(1)** underneath the filter.
- Close the two valves **(2)**, one on each side of the filter housing.
- Open the drain valve **(3)** to empty the filter vessel.
- Unscrew the filter vessel **(4)** carefully.
- Take the filter element **(5)** out and clean it or change it whatever is necessary.
- Install the filter element again, and mount the filter vessel **(4)** observing that the O-ring **(6)** is properly fitted in the groove of the filter vessel.
- Close the valve **(3)** and open the valves **(2)** again.
- Before starting the processor open valve **(3)** and drain out app. 100 ml.
(The drained out solution should be poured back into the respective section).

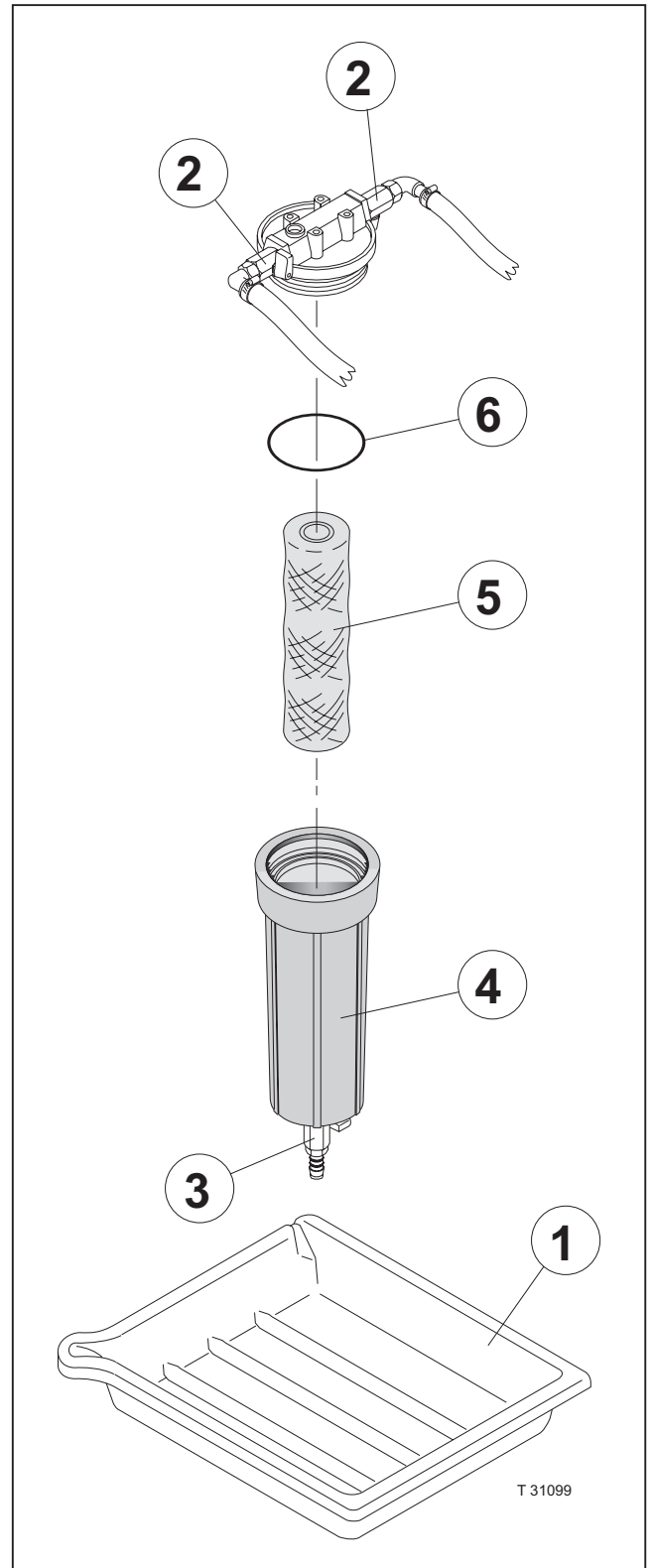

CLEANING, DEVELOPER SECTION

NORMAL CLEANING

Accessories:

- Lint free cloth

Cleaning agents:

- Developer solution.
- Warm water.
- Moisten the cloth with developer.
- Remove all rollers and guides from the developer section and wipe them with the cloth.
- Rinse all parts with warm water and dry them with a dry cloth.
- Reinstall all parts in their original positions.

MAJOR CLEANING

The major cleaning procedure should prevent building up of developer deposits on rollers and guides and in tubes, hoses, pumps, and valves etc.

Accessories:

- Lint free cloth
- Soft brush
- Longhandled bottle brush
- Thin wire (ex a paper clip).

Cleaning agents:

- 5% nitric acid.
- 10% citric acid.
- Warm water.

- Drain the developer section down to a level of app. 3 cm. The developer section should be drained into a waste container.
- Remove spray tube, rollers and guides from the section and clean them separately:
 - Clean rollers and guides with developer or if necessary let them soak in 10% citric acid for a while. Then rinse them with warm water and dry them.
Use the bottle brush to clean the inside of the spray tubes.
Clean the holes in the spray tube using the paper clip.
 - Clean the developer filter with water.
(See “CHANGING/CLEANING OF FILTERS” earlier in this chapter.)
- Remove any deposits from the tank walls and bottom using the brush.
- Drain the remaining developer.
- Rinse the tank with warm water and drain it.
- Fill the tank with app. 16 liters of fresh developer.
- Reinstall all parts in their proper positions.

If tank is heavily polluted:

- Remove any incrustations with 5% nitric acid.
- Fill tank with 15 l of 10% citric acid.
- Set dev. temp. to 40°C and let the processor run for 20 minutes in “STAND-BY” mode.
- Switch off the processor and drain it.
- Repeat the procedure with 15 l of water.

CHANGING THE DEVELOPER

The developer solution should be changed regularly to maintain the processing quality of the processor. Ask your chemicals supplier for intervals.

(See illustration below).

- Shut down the processor completely. (See “SHUTDOWN PROCEDURE” in chapter 3 earlier in this manual).
- Lead the developer drain hose (1) into an empty waste container of min. 20 liters.
- Open the drain valve (2).
- When tank is empty clean it if necessary (see description earlier in this chapter).

- Drain developer filter and exchange or clean the filter element as described in “CHANGING/CLEANING OF FILTERS” earlier in this chapter).
- Close the valve (2).
- Fill the developer tank with app. 16 liters of ready mixed developer solution.

NOTE! It will be necessary to top up the level in the developer section shortly after start-up as the filter vessel now will be filled with developer solution.

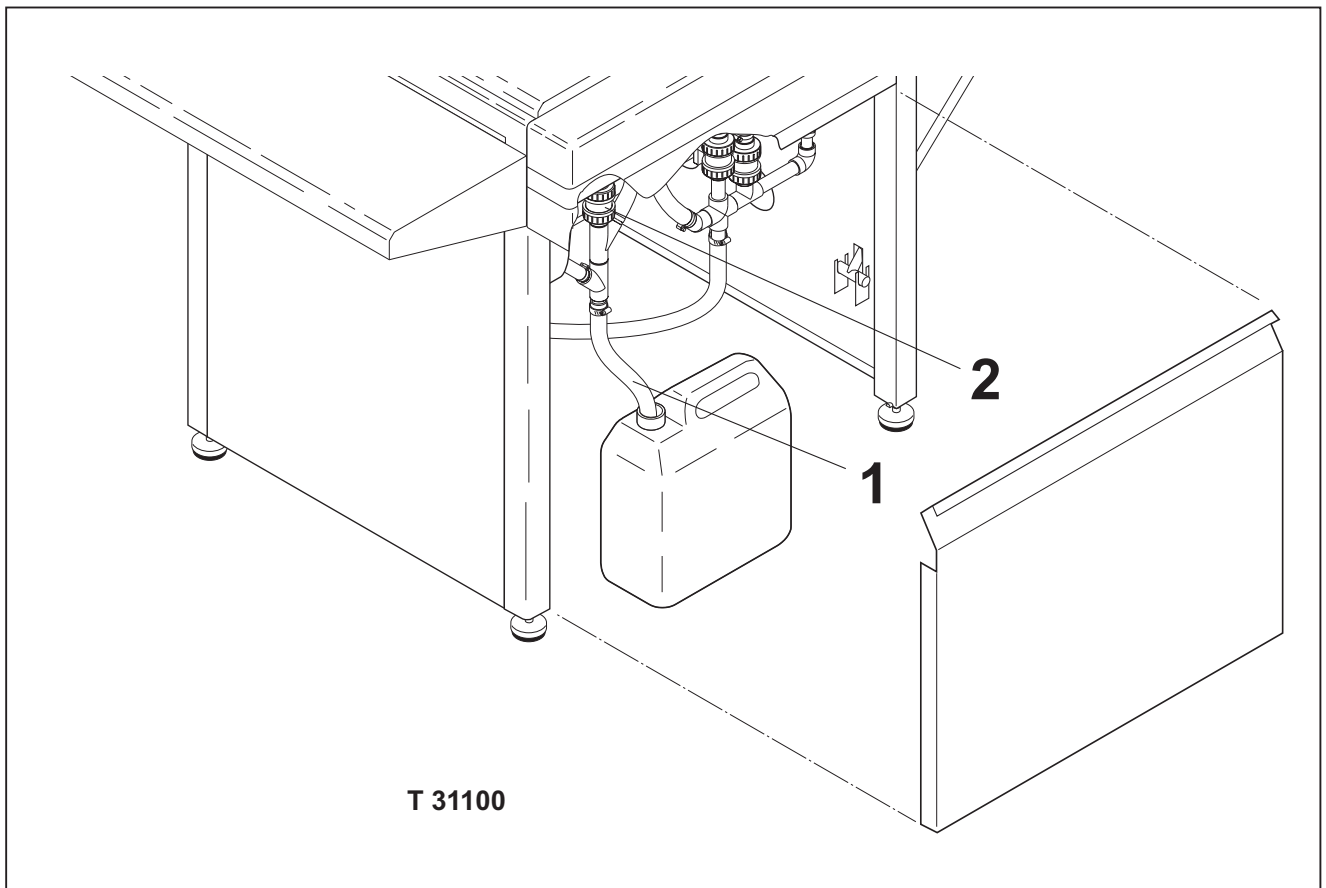

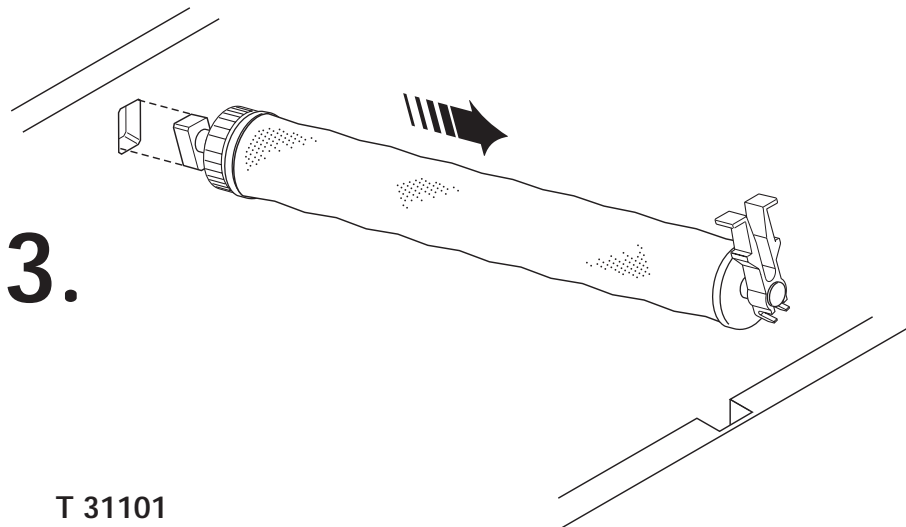
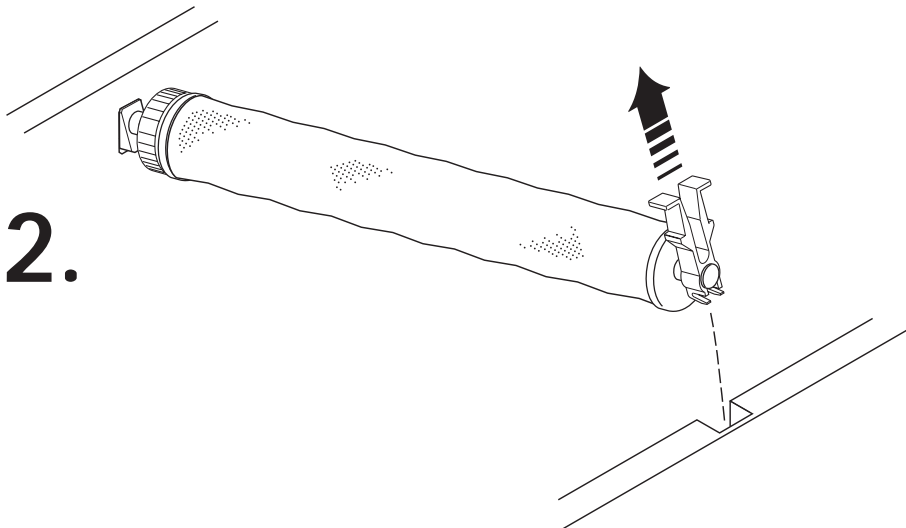
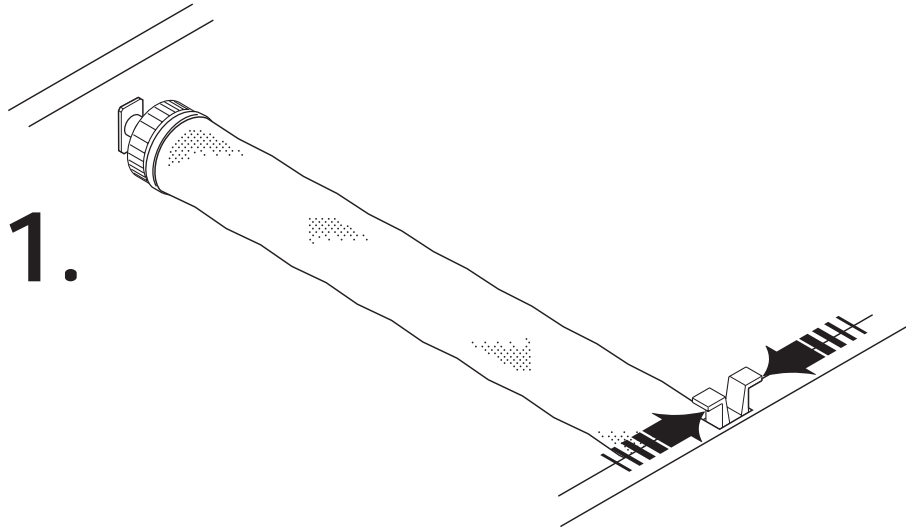

T 31101

REMOVING THE BRUSH/STOP ROLLER

When performing any cleaning or servicing in the wash-off section it will be necessary to remove the brush (or stop roller).

The procedure is as follows:
(See illustration opposite)

STEP 1:

Push together the clamps of the special bearing in the right side.

STEP 2:

Lift out the brush/roller in the right side.

STEP 3:

Pull out the brush/roller and the small bearing from the left tank side.

Reinstall the brush/roller in reverse order making sure that

- the small bearing in the left side is fitted properly in the respective hole.
- both of the clamps of the special bearing locks properly in the tank wall.

REPLACING THE BRUSH ROLLER CLOTH

The brush roller cloth can be replaced in case of heavy fouling or wear.

(See illustration below).

- Take out the brush roller as described in “REMOVING THE BRUSH/STOP ROLLER”.
- Dismount the special bearing (1) by pulling it upwards.
- Unscrew the disc (2) and loosen the disc (3).
- Pull off the cloth (4).
- Apply the new cloth (use talcum), wrap it round the roller edge in the gear wheel end and tighten the disc (3).
- Stretch the cloth to obtain a smooth fit along the roller, wrap it round the roller edge and hold it while tightening the disc (2).
- Fit the special bearing to the roller making sure of correct orientation of the spring clamp.
- Reinstall the brush roller.

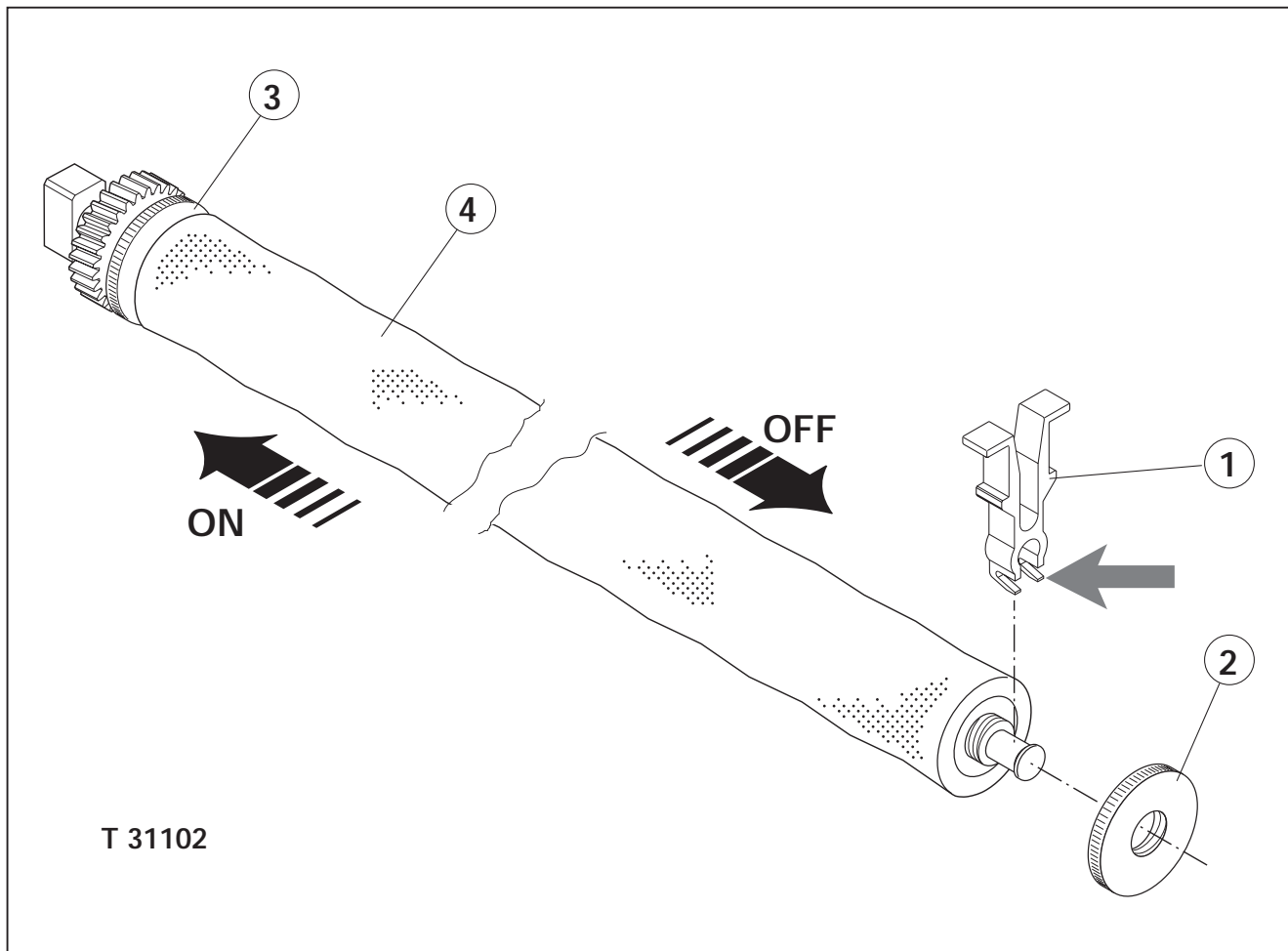

CLEANING, WASH-OFF SECTION

Accessories:

- Lint free cloth
- Brush
- Long handled bottle brush

Cleaning agents:

- Biocide or strong alkalic liquid.
(To remove any algae-, fungal- or bacterial growth).
 - Warm water.
- Drain both of the wash-off sections down to a level of app. 3 cm. The solution should be drained into a waste container.
 - Remove spray tubes, rollers and guides from the sections and clean them separately:
 - Clean rollers and guides with warm water and dry them.
Use the bottle brush to clean the inside of the spray tubes.
Clean the holes in the spray tube using the paper clip.
 - Clean the wash-off filters with water.
(See “CHANGING/CLEANING OF FILTERS” earlier in this chapter.
 - Remove any deposits from the tank walls and bottom using the brush.
 - Drain the remaining solution.
 - Rinse the tank with warm water and drain it.
 - Fill the sections with fresh solution until it starts to overflow.
 - Reinstall all parts in their proper positions.

CHANGING THE WASH-OFF SOLUTION

The wash-off solution should be changed regularly to maintain the processing quality of the processor. Ask your chemicals supplier for intervals.

(See illustration below).

- Shut down the processor completely. (See “SHUTDOWN PROCEDURE” in chapter 3 earlier in this manual).
- Lead the wash-off drain hose (1) into an empty waste container of min. 20 liters.
- Open the drain valves (2) and (3).
- When tank is empty clean it if necessary (see description earlier in this chapter).

- Drain wash-off filters and exchange or clean the filter elements as described in “CHANGING/CLEANING OF FILTERS” earlier in this chapter).
- Close the valve (2) and (3).
- Fill the sections with fresh solution until it starts to overflow.

NOTE! It will be necessary to top up the level in the wash-off sections shortly after start-up as the filter vessels now will be filled with wash-off solution.

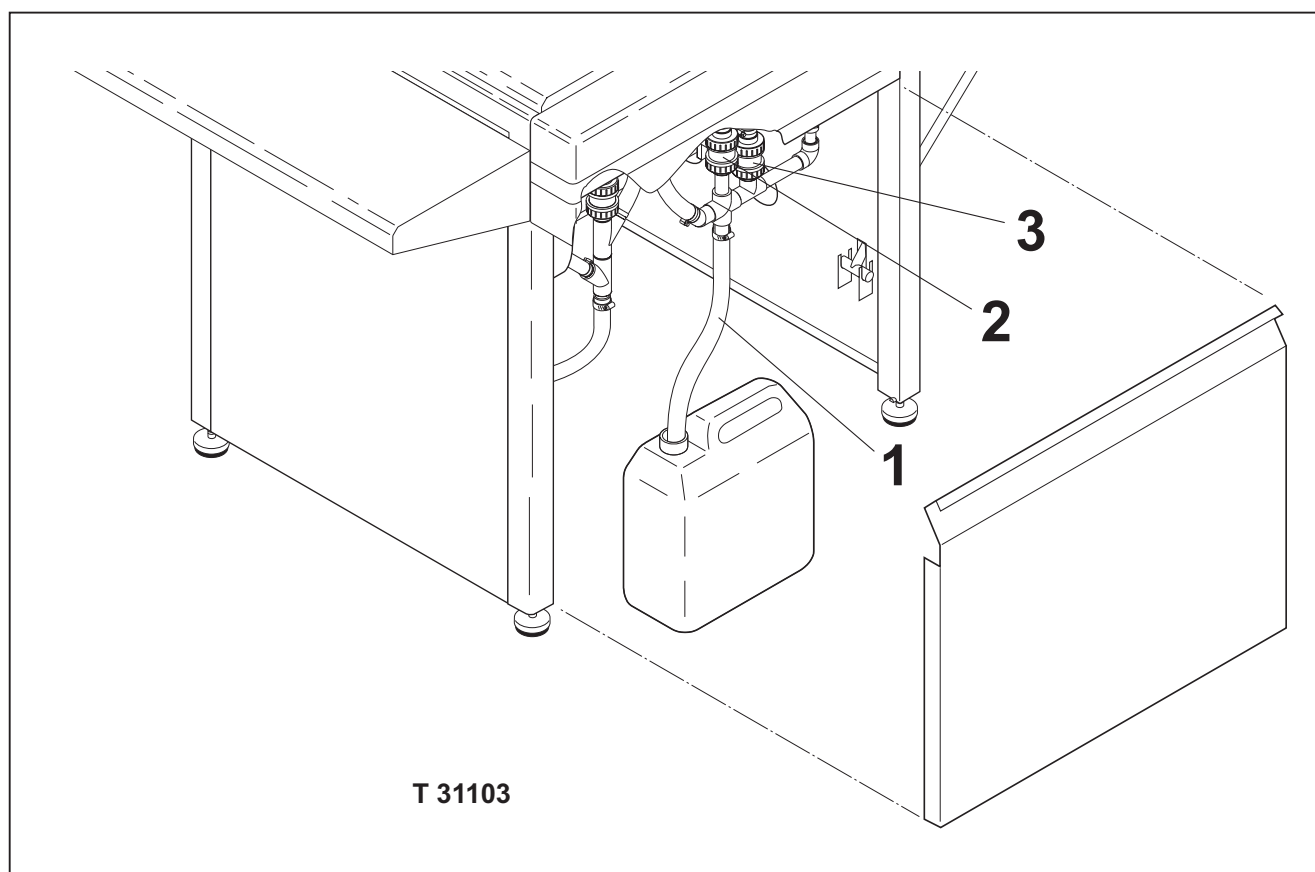

CLEANING, GUM SECTION

NORMAL CLEANING

When the processor is in "STAND-BY" the gumming function runs at intervals to prevent sticking of the gum rollers.

Additionally it is recommended to run the automatic "GUM-RINSE" program every day when shutting the processor down.

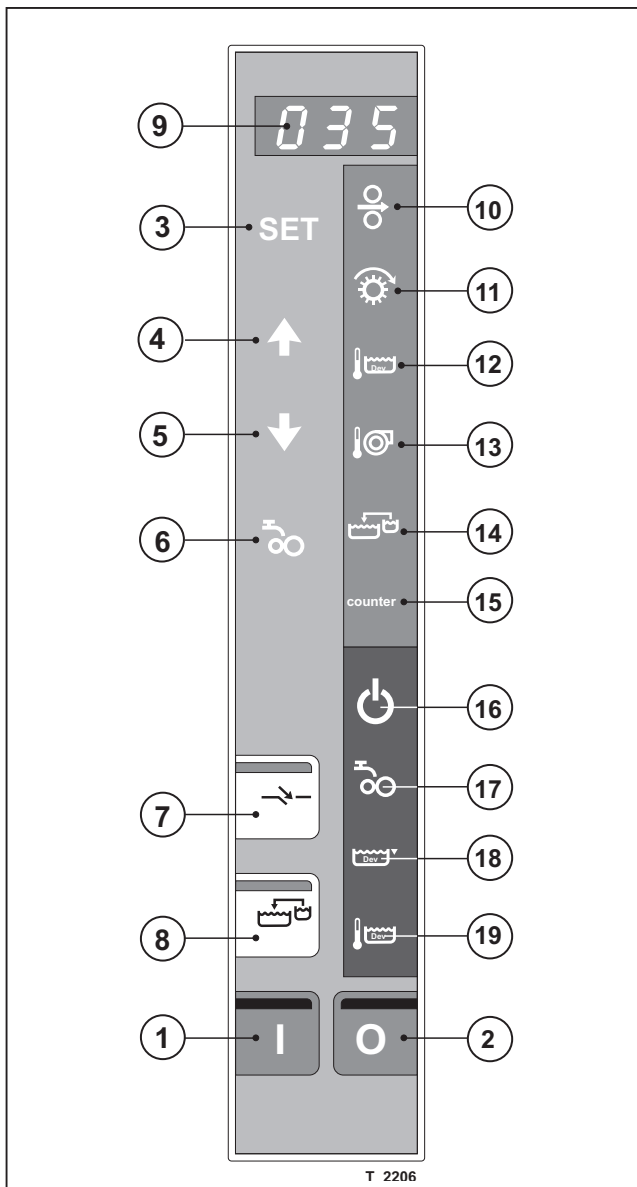

RUNNING THE GUM-RINSE PROGRAM

NOTE! The "GUM-RINSE" program should be performed at least once a day.

- The processor must be in "STAND-BY" mode.
- Press the "GUM-RINSE" button (6) and hold it for 3 secs.
- The "GUM-RINSE" program starts, the "GUM-RINSE" lamp (17) and the "WAIT" lamp (16) will start to flash asynchronously ("WAIT" lamp is on when the "GUM-RINSE" lamp is off and opposite).
- The display will show the current code for the AUTO-start function for 10 secs.:
 - A - AUTO-start switched on
 - O - AUTO-start switched off.Within the 10 secs. you can change the current code by pushing the "SET" button (3) and change the code by means of the selection buttons (4) or (5). Push "SET" (3) again to confirm new setting. The display will turn off after app. 10 secs.
- To skip the rinse programs before time-out push the "OFF" button (2).

NOTE! If rinse program is skipped before time-out, wait for app. 1 min. before switching off the processor.

- When the rinsing part of the program is finished the "ON" lamp (1) turns off and the "OFF" lamp (2) starts to flash indicating that the gum section is being emptied. After 1 min. the processor automatically switches to "OFF" mode.

WEEKLY CLEANING

Accessories:

- Soft brush

Cleaning agents:

- Warm water

- Remove the rollers and the gum spray tube from the gum section and clean them in water.
- Wash the tank with warm water and a brush.
- Reinstall all parts again, observing that all parts are reinstalled in their proper place.

CLEANING OF THE GUM GRATE

(See illustration below).

The processor is equipped with a special grate in the drain opening of the gum section. The grate is designed to prevent the gum solenoid valve from being blocked if something mistakenly drops into the opening.

The grate should be taken out regularly and cleaned.

Remember to reinstall after cleaning.

